

THE PNEUMATIC IMPACT WRENCHES SMP, SMS

DESCRIPTION:

The pneumatic impact wrenches SMP and SMS are used for loosening and tightening of bolted connections in the mining and heavy industries. The tightening torque is produced by a multi-plate motor that transfers the torque to the impact hammer mechanism.

The pneumatic impact wrenches meet conditions for use in the I M2 explosive danger environment set by the EN 1127-2 standard.

The pneumatic impact wrenches SMP and SMS consist of the following basic parts:

- Complete control handle
- Complete drive
- Complete hammer mechanism



SMS 210



SMP 038

TECHNICAL PARAMETERS:

		SMP 026	SMP 068	SMP 140	SMS 210	SMS 260
Operating pressure	[MPa]	0,4 – 0,6				
Maximum torque	[Nm]	260	680	1400	2100	2600
Air consumption	[m ³ min ⁻¹]	0,67	0,8	1,9	2	1,37
Tenon size	[mm]	½"	¾"	¾"	1"	
Filtration	[µm]	50				
Basic dimensions (l x h)	[mm]	168 x 190	199 x 244	238 x 410	367 x 135	367 x 135
Weight	[kg]	3,1	5,4	9	10,5	10,5
Inside diameter of the supply hose	[mm]	Js 10	Js10	Js 16	Js 16	Js 16

THE PNEUMATIC BOOSTER (MULTIPLICATOR) NMP 3200

DESCRIPTION:

The pneumatic booster (multiplier) NMP 3200 is used for loosening and tightening of screw connections in the heavy industry. Its torque is supplied by the multi-plate motor that transfers the torque to the outlet 1 1/2" driver using planetary gears. The tightening torque setting is done by regulation of the supply pressure.

The pneumatic NMP 3200 booster (multiplier) does not contain light metal alloys and can be used in the explosive danger environment (EX I M2 c IIB 95C X and EX II 2 GD c IIB 95C according to the new European standard 94/9/EC and the standard 1999/92/EC – usually called ATEX).



tlak MPa	Mk výstup [Nm]	
	motor n=0	motor Pmax.
0,63	10116	5058
0,6	9556	4778
0,55	8756	4378
0,5	8115	4058
0,45	7635	3817
0,4	6834	3417
0,35	5954	2977
0,3	5233	2617

Torque is limited by the safety clutch to 3200Nm

TECHNICAL PARAMETERS:

Operating pressure	[MPa]	0,1 – 0,63
Maximum torque	[Nm]	table
Air consumption	[m ³ min ⁻¹]	1,1
Driver size	[mm]	1"
Filtration	[µm]	50
Weight	[kg]	18
Inside diameter of the supply hose	[mm]	Js 10

THE ANTI-EXPLOSION VPN 42 PNEUMATIC DRILL

DESCRIPTION:

The anti-explosion VPN 42 pneumatic drill is used to drill holes up to Ø42mm in soft and medium-hard rocks. The drill is equipped by water irrigation to reduce dust.

The anti-explosion VPN 42 pneumatic drill meets conditions for use in the I M2 explosive danger environment set by the EN 1127-2 standard.

The anti-explosion VPN 42 pneumatic drill consists of the following basic parts:

- Body with trigger 0023 PD 1000
- Pneumatic motor 0023 PD 2000
- Working part 0023 PD 3000

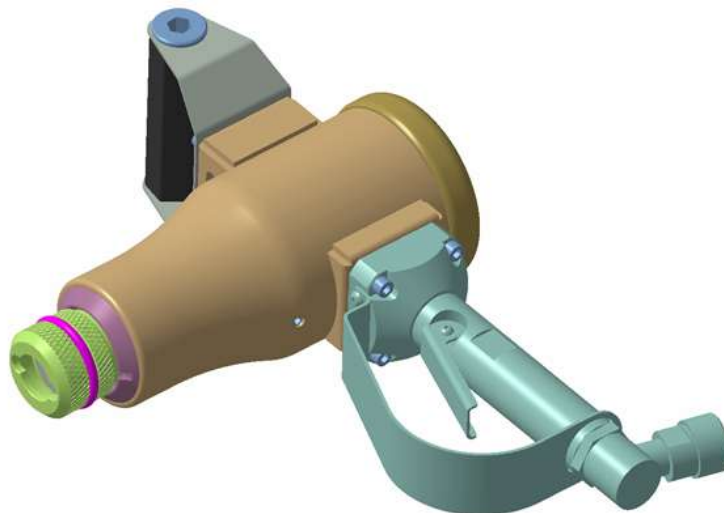

TECHNICAL PARAMETERS:

Operating pressure	[MPa]	0,4 – 0,6
Maximum water pressure	[MPa]	0,6
Air consumption	[m ³ min ⁻¹]	3,8
Max. output	[kW]	3 ±10%
Max. diameter of the bit	[mm]	42
RPMs	[min ⁻¹]	1100
Kroutící moment	[Nm]	28
Filtration	[µm]	50
Basic dimensions (l x h)	[mm]	344 x 295
Weight	[kg]	9,6
Inside diameter of the supply hose	[mm]	Js19/Js10

THE ANTI-EXPLOSION DP 220 PNEUMATIC DRILL

DESCRIPTION:

The anti-explosion DP 220 pneumatic drill is used to drill holes up to Ø42mm in soft and medium-hard rocks. The drill is equipped by water irrigation to decrease dustiness.

The anti-explosion DP 220 pneumatic drill meets the conditions for use in the I M2 explosive danger environment set by the EN 1127-2 standard.

The anti-explosion DP 220 pneumatic drill consists of the following basic parts:

- Body with trigger
- Pneumatic motor
- Working part



TECHNICAL PARAMETERS:

Operating pressure	[MPa]	0,4 – 0,6
Maximum water pressure	[MPa]	0,6
Air consumption	[m ³ min ⁻¹]	2,7
Max. output	[kW]	2,2 ±10%
Max. diameter of the bit	[mm]	42
Max. revolutions	[min ⁻¹]	1100
Torque	[Nm]	20
Filtration	[µm]	50
Basic dimensions (l x h)	[mm]	292 x 385
Hmotnost	[kg]	7,6
Inside diameter of the supply hose	[mm]	Js19/Js10

PNEUMATIC STANDING DRILL VSP 1

DESCRIPTION:

The pneumatic standing drill VSP 1 is used to drill holes up to Ø51mm in soft and medium hard rocks. The drill is equipped with water flushing and the possibility to use self-burrowing hydraulic bolts (expansion of hydraulic bolts immediately after burrowing) to lower dust creation. A steel rest that presses the grate against ceiling and using expansion cylinder pressure secures the ceiling against falling rocks and thus provides operator's safety is placed in the casing and used to guide the drill rod.

The pneumatic standing drill VSP1 meets the conditions for use in the I M2 explosive danger environment set by the EN 1127-2 standard.

The pneumatic standing drill VSP1 consists of the following basic parts:

- Pneumatic reversible drill
- Fixed column with expansion cylinder
- Drill travel
- Control handle

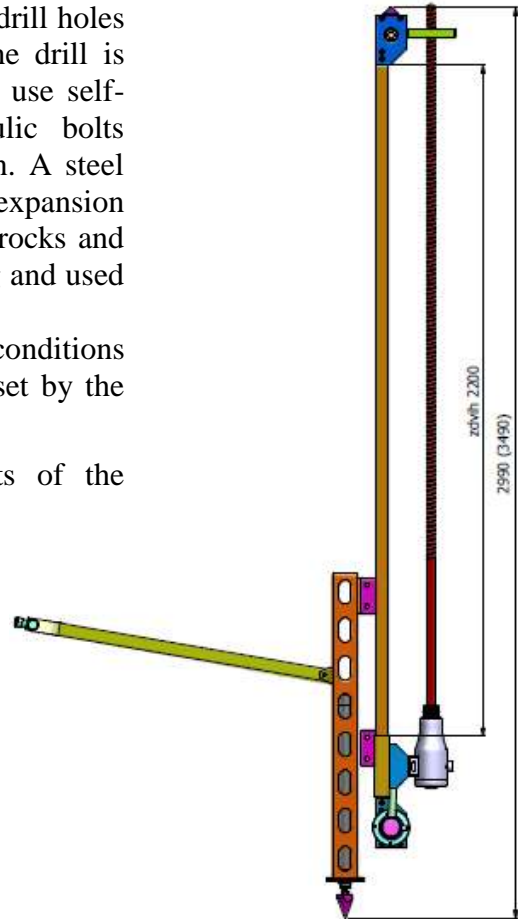

TECHNICAL PARAMETERS:

Operating pressure	[MPa]	0,4 – 0,6
Maximum water pressure/bolt expansion	[MPa]	0,6/30
Air consumption	[m ³ min ⁻¹]	2,7
Max. output	[kW]	3 ±10%
Column pressure	[N]	1500
Drill pressure	[N]	1000
Max. revolutions	[min ⁻¹]	1100
Torque	[Nm]	28
Filtration	[µm]	50
Basic dimensions (l x h)	[mm]	
Weight	[kg]	Approx. 40kg
Inner diameter of inlet hose (air/water)	[mm]	Js19/Js10

PNEUMATIC TURBO DRILL DPT 450-011BXOEX

DESCRIPTION:

The pneumatic turbo drill DPT 450-011BXOEX is used for manual drilling with a drill rod equipped by a drill bit. The drill guarantees effective and economical work during industrial use in continuous operation even in environments with explosion danger (meets the IM2c II2GcIIBT6(80°C)X conditions). Drilling into soft and medium hard coal, shale or other soft rocks was never simpler.

The main technical difference against competition drills is use of a turbine engine. Another unique feature of this drill is the use of a belt in the first part of the gear to seal its oil contents during high speeds.

Due to its high gear ratio this drill achieves the torque of 45 Nm at maximum power and 105 Nm when stopped. A regulator of this drill works without air pressure that would influence its operation.

This drill is ready for drilling without water flushing. The lever start with safety is equipped by the 60 micron filtration. The exhaust points forward in the direction of spindle. Additional handle is used also as an anchor for a drill support. The drill rod clamp system is a flat hexagon – with an option to change according to customer's wishes or used drill rod ending. We recommend using an external filter to extend the drill service life.

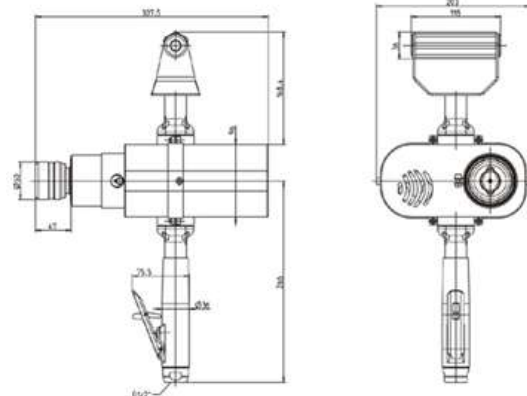

TECHNICAL PARAMETERS:

Operating pressure	[MPa]	0,4 – 0,6
Max. air consumption at idle/max. output	[m ³ min ⁻¹]	1,25/4,3
Max. output	[kW]	4,5 ±10%
Max. diameter of the bit	[mm]	42
Max. revs. at idle/max. output	[min ⁻¹]	1100/900
Torque	[Nm]	45
Filtration	[µm]	50
Weight	[kg]	8,7
Inside diameter of the supply hose	[mm]	Js19

THE PNEUMATIC DRILLS PV 13, 16

DESCRIPTION:

The pneumatic drills PV 13 and 16 are used for drilling holes into iron or non-metallic materials. They are used in machining, automotive and similar industries.

The drills consist of the pneumatic multi-plate motor that is seated in aluminum body with a handle, planetary transmission and output shaft where various type working tools are attached.



PV 13B



PV 16B

TECHNICAL PARAMETERS:

		PV 13B	PV 13C	PV 16B
Idle revs 1st gear / 2nd gear	min ⁻¹	1.450 / 1.950	350	600 / 850
Max. output 1st gear / 2nd gear	kW	0,45 / 0,50	0,35	0,45 / 0,50
Idle air consumption 1st gear / 2nd gear	m ³ .min ⁻¹	0,45 / 0,90	0,95	0,45 / 0,90
Air consumption	m ³ .min ⁻¹	0,7	0,8	0,7
Operating pressure	MPa	0,6	0,6	0,6
Inside diameter of the supply hose	mm	10	10	10
Chuck range	mm	2,0 - 13,0	2,0 - 13,0	3,0 - 16,0
Inside diameter of the supply hose	mm	13	13	16
Max. diameter of drill bit for Aluminum and plastics	mm	13	13	23
Weight	kg	2,45	1,95	3,15
Basic dimensions (l x h)	mm	230 x 167	246 x 189	290 x 167

THE PNEUMATIC DRILLS PV 32 AND PVR 32

DESCRIPTION:

The pneumatic drills PV 32 and PVR 32 are used for drilling holes into iron or non-metallic materials. They are used in machinery industry, construction etc.

The drills consist of the pneumatic multi-plate motor that is seated in aluminum body, handle with a lever controls, and the cover with planetary transmission.



PV 32



PVR 32

TECHNICAL PARAMETERS:

		PV 32A-04X	PVR 32A-04X
RPMs	min ⁻¹	380	380
Max. output	kW	1,85	1,45
Air consumption	m ³ . min ⁻¹	2,1	2,4
Operating pressure	MPa	0,6	0,5-0,6
Inside diameter of the supply hose	mm	19	19
MORSE cone		3	3
Max. diameter of steel drill bit	mm	32	32
Max. diameter of drill bit for Aluminum and plastics	mm	32	32
Weight	kg	9,5	9,40
Basic dimensions (l x h)	mm	335 x 410	335 x 410

THE REVERSIBLE PNEUMATIC DRILL VPR 20FE

DESCRIPTION:

The reversible pneumatic drill VPR 20Fe is used to drill up to 20mm diameter holes in steel and other materials.

The VPN 42 reversible pneumatic drill meets conditions for use in the I M2 explosive danger environment set by the EN 1127-2 standard.

The VPN 42 reversible pneumatic drill consists of the following basic parts:

- Body with motor and trigger 0030 PD 1000
- Working part 0030 PD 2000

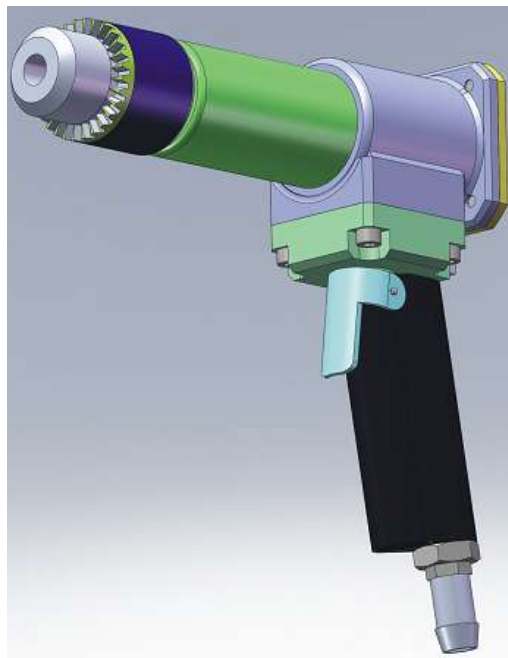

TECHNICAL PARAMETERS:

Operating pressure	[MPa]	0,4 – 0,6
Air consumption	[m ³ min ⁻¹]	0,8
Max. output	[kW]	0,6
Max. diameter of the bit	[mm]	20
RPMs	[min ⁻¹]	500
Filtration	[µm]	50
Basic dimensions (l x h)	[mm]	210 x 200
Weight	[kg]	3,5
Inside diameter of the supply hose	[mm]	Js10

THE VPU 23 ANGULAR PNEUMATIC DRILL

DESCRIPTION:

The VPU 23 angular pneumatic drill is used for drilling and rounding up holes of up to Ø23mm diameter in steel. Thrust of the 60mm max. length spacer bolt can be used while drilling.

The VPU 23 angular pneumatic drill consists of the following basic parts:

- Body with motor
- Complete control handle
- Angular transmission with chuck



TECHNICAL PARAMETERS:

Operating pressure	[MPa]	0,4 – 0,6
MORSE cone		MORSE 2
Air consumption	[m ³ min ⁻¹]	1,6
Max. output	[kW]	1,5 ±10%
Max. diameter of steel drill bit	[mm]	23
RPMs	[min ⁻¹]	280
Filtration	[µm]	50
Basic dimensions (l x h)	[mm]	446 x 193
Weight	[kg]	8,3
Inside diameter of the supply hose	[mm]	Js15

THE PBO DIRECT PNEUMATIC GRINDERS

DESCRIPTION:

The PBO direct pneumatic grinders are used to grind welds in the machining industry, for grinding lugs or bosses in foundry industry etc.

They consist of the working part with the grinding wheel tightened to it, body with the multi-plate motor and control handle.



PBO 50



PBO 150

TECHNICAL PARAMETERS:

		PBO 100	PBO 150	PBO 180	PBO 230
RPMs	min ⁻¹	8500	5700	8500	6600
Max. output	kW	1,5	2,4	1,5	2,4
Spotřeba vzduchu naprázdno	m ³ . min ⁻¹	0,5	0,7	0,5	0,7
Air consumption	m ³ . min ⁻¹	1,55	1,9	1,5	1,9
Operating pressure	MPa	0,6	0,6	0,6	0,6
Inside diameter of the supply hose	mm	13	16	13	16
Weight	kg	3,7	5,1	4	5
Basic dimensions (l x h)	mm	74 x 523	90 x 537	74 x 510	74 x 510

THE PBU ANGULAR PNEUMATIC GRINDERS

DESCRIPTION:

The PBU angular pneumatic grinders are used for grinding steel materials in the machine-building industry, grinding of lugs in the foundry industry etc.

The PBU angular pneumatic grinders consist of the body with the multi-plate motor, control handle and the working part with a grinding wheel.



PBU 180E



PBU 150

TECHNICAL PARAMETERS:

		PBU 115C	PBU 150G	PBU 180E	PBU 230E
RPMs	min ⁻¹	13200	10200	8500	6600
Max. output	kW	0,5	1,9	2,4	2,4
Spotř. vzduchu naprázdno	m ³ . min ⁻¹	0,52	0,9	1,1	0,7
Air consumption	m ³ . min ⁻¹	0,82	1,8	2,2	2
Operating pressure	MPa	0,6	0,6	0,6	0,6
Inside diameter of the supply hose	mm	10	16	16	16
Weight	kg	1,8	4	5,5	5,5
Basic dimensions (l x h)	mm	160 x 157	234 x 192	335 x 220	335 x 200

THE SEK IMPACT HAMMERS

DESCRIPTION:

THE SEK impact hammers have all-round use and are used for example in:

- Construction – light demolition work, cutting grooves, and removing of plaster
- Foundry industry – cleaning of cast pieces, cutting of lugs
- Stone cutting - wedging, dressing and so on

The SEK impact hammers consist of the control handle, cylinder with piston and ring valves. The air exhaust is muffled through a rubber muffler.



SEK 2



SEK 5



SEK 6

TECHNICAL PARAMETERS:

	Weight	Basic dimensions	Air consumption	Tool stop	Operating pressure	Connection thread
	[kg]	[mm]	[m ³ · min ⁻¹]	[mm]	[bar]	
SEK 2-1 CP	2,2	155 × 220	0,3	Ø 12,5 # 10,8 × 45	4-6	G 1/2 "
SEK 4-1 CA	4	225 × 353	0,2	# 19 × 50	4-7	G 1/2 "
SEK 5-2 CA	5	230 × 355	0,7	# 19 × 50 ¹⁾	4-7	G 1/2 "
SEK 5-2 BL	4,85	230 × 300	0,7	²⁾	4-7	G 1/2 "
SEK 6-2 CA	5,7	230 × 453	0,6	# 19 × 50 ¹⁾	4-7	G 1/2 "
SEK 6-2 BL	5,55	230 × 350	0,6	²⁾	4-7	G 1/2 "

THE SK 9 AND SK 13 IMPACT HAMMERS

DESCRIPTION:

THE SK 9 AND SK 13 IMPACT hammers are used to break down less and medium-hard rocks and materials (for example concrete, bituminous roads, coal etc.), during construction work and in mining and surface operations.

The jackhammers consist of the control handle, cylinder with piston and ring valves. The air exhaust is muffled through a rubber muffler.



SK 9-5

TECHNICAL PARAMETERS:

	Weight	Basic dimensions	Air consumption	Tool stop	Operating pressure	Connection thread
	[kg]	[mm]	[m ³ · min ⁻¹]	[mm]	[bar]	
SK 9-5	9	210 × 470	0,9	Ø 25 × 75	4–6	R 3/4 "
SK 9-6	9	210 × 470	0,9	# 22 × 82	4–6	R 3/4 "
SK 9-6 A	10	210 × 470	0,9	# 22 × 82	4–6	R 3/4 "
SK 13 B	13	236 × 612	0,9	Ø 25 × 75	4–7	R 3/4 "
SK 13 D	12	271 × 604	0,9	# 22 × 82	4–7	R 3/4 "
SK 13 DZ	12	271 × 604	0,9	# 22 × 82	4–7	R 3/4 "

THE SKA 10 AND SKA 12 JACKHAMMERS with decreased vibrations

DESCRIPTION:

THE SKA 10 AND SKA 12 JACKHAMMERS with decreased vibration are used to break down less and medium-hard rocks and materials (for example concrete, bituminous roads, coal etc.), during construction work and in mining and surface operations.

The jackhammers consist of the spring-cushioned handle with control and integrated oil lubricating, cylinder with piston and ring valves. The air exhaust is muffled through a rubber muffler.



SKA 10B

TECHNICAL PARAMETERS:

	Weight	Basic dimensions	Air consumption	Tool stop	Operating pressure	Connection thread
	[kg]	[mm]	[m ³ · min ⁻¹]	[mm]	[bar]	
SKA 12 B	12	210 × 650	1,0	Ø 25 × 75	4-7	R 3/4 "
SKA 10 B	10	210 × 490	0,9	Ø 25 × 75	4-7	R 3/4 "
SKA 10 D	10	210 × 490	0,9	# 22 × 82	4-7	R 3/4 "
SKA 10 DZ	10	210 × 490	0,9	# 22 × 82	4-7	R 3/4 "
SKA 12 D	12	210 × 650	1,0	# 22 × 82	4-7	R 3/4 "
SKA 12 DZ	12	210 × 650	1,0	# 22 × 82	4-7	R 3/4 "

THE BKA DEMOLITION HAMMERS

DESCRIPTION:

THE BKA DEMOLITION hammers with reduced vibration are used to break down less and medium hard rocks and materials (for example concrete, bituminous roads, coal etc.), during construction work and in mining and surface operations. They are suitable for vertical or inclined work by their arrangement and weight.

The demolition hammers consist of the spring-cushioned handle with control and integrated oil lubricating, cylinder with piston and ring valves. The air exhaust is muffled through a rubber muffler

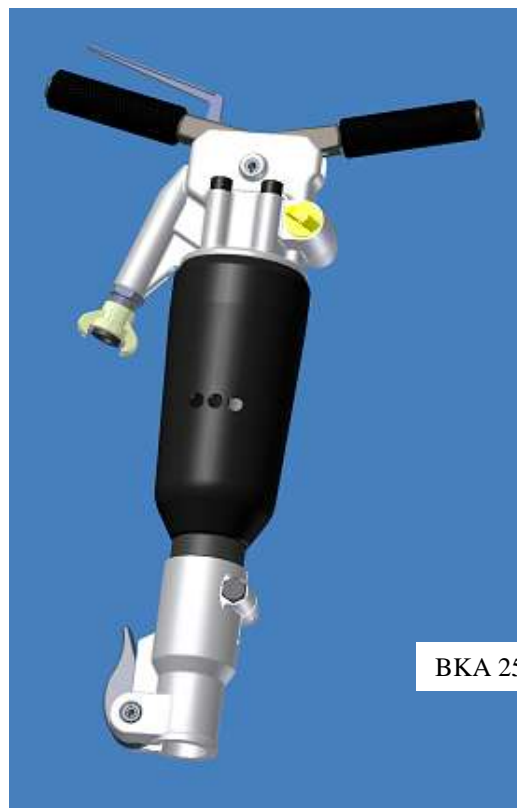

TECHNICAL PARAMETERS:

	Weight	Basic dimensions	Air consumption	Tool stop	Operating pressure	Connection thread
	[kg]	[mm]	[m ³ · min ⁻¹]	[mm]	[bar]	
BKA 15	15	455 × 635	0,8	# 22 × 82(# 25 × 108)	4-7	R 3/4 "
BKA 20	21	455x640	1,4	# 25 × 108 (# 28 × 160)	4-7	R 3/4 "
BKA 25	25	455 × 640	1,8	# 25 × 10(#28×160)(#32×160)	4-7	R 3/4 "
BKA 30	30	455 × 730	1,5	# 32 × 160	4-7	R 3/4 "

THE PNEUMATIC DRILL HAMMERS BH 5 AND BH8

DESCRIPTION:

The pneumatic drill hammers BH 5 and BH8 belong to the light drill hammer weight category and are used to drill holes for blasting operations in rocks with various hardnesses, primarily in mines, then in road and railroad construction, in building construction etc.

The pneumatic drill hammers BH 5 and BH8 consist of the firm handle with a lever, cylinder with piston and the cylinder cover with a drill case.



BH 5



BH 8

TECHNICAL PARAMETERS:

	Weight	Basic dimensions	Air consumption	Tool stop	Operating pressure
	[kg]	[mm]	[m ³ · min ⁻¹]	# [mm]	[bar]
BH 5	5	475 × 405	0,55	19 × 50	4–6
BH 8	8,4	150 × 420	0,64	19 × 82,5	4–6
BH 8	8,4	150 × 420	0,64	22 x 82,5	4–6

THE VK DRILL HAMMERS

DESCRIPTION:

THE VK drill hammers belong to the medium weight drill hammer category and are used to drill holes for blasting operations in rocks with various hardnesses, primarily in mines, then in road and railroad construction, building construction etc.

The VK drill hammers consist of the firm or spring-cushioned handle with control, cylinder with piston and the cylinder cover with a drill case.



VK 15 RO



VK 22



NVK 0,3

TECHNICAL PARAMETERS:

	Weight	Basic dimensions	Air consumption	Tool stop	Operating pressure
	[kg]	[mm]	[m ³ · min ⁻¹]	# [mm]	[bar]
VK 15 RO	17,1	475 × 645	2,2	19 × 108	4–6
VK 15-1 RO	17,1	475 × 645	2,2	22 × 108	4–6
VK 15-3	15,5	170 × 645	2,2	# 19 × 108	4–6
VK 15-4	15,5	170 × 645	2,2	# 22 × 108	4–6
VK 19	21,5	270 × 685	2,7	22 × 108	4–6
VK 22-1	23,5	280 × 720	4	22 × 108	4–6
NVK 0,3	26	280 × 680	4,3	22 × 108	3-4,5
VK 29-2	26	280 × 720	4	22×108, 25×108	4–6

THE VP DRILL SUPPORTS

DESCRIPTION:

THE VP drill SUPPORTS are used with manual pneumatic drill hammers tailored to drill using pneumatic supports, for example, VK 22, NVK 0,3, VK 29 and such.

THE VP drill SUPPORTS consist from the spring-cushioned upper extendable part with a handle and control and the firm part with a spur that is used to support the drill supports while working. The extendable part is sealed using several leather sleeves that prevent pressure air leaks from the support.



TECHNICAL PARAMETERS:

	Weight	Max. extension length	Max. thrust	Operating pressure
	[kg]	[mm]	[N]	[bar]
VP 600-1	16,9	600	1000	4-6
VP 800-1	19,0	800	1000	4-6
VP 1000-1	20,7	1000	1000	4-6
VP 1200-1	22,4	1200	1000	4-6

THE YSP 45 PNEUMATIC BOLT DRILL

DESCRIPTION:

The YSP pneumatic bolt drill is used in mining, stone quarries, in tunneling and other work related to drilling holes for explosives and anchoring of ceiling. The drill range is 60° - 90 °. The drill is intended for drilling of medium to medium-hard rocks with 34 mm – 42 mm diameter drill bits and length of the hole 6 m. The drill is equipped by a water flushing.

The YSP bolt drill meets conditions for use in the I M2 explosive danger environment set by the EN 1127-2+A1 standard.



TECHNICAL PARAMETERS:

Operating pressure	[MPa]	0,4 – 0,63
Water pressure	[MPa]	0,3
Maximum torque	[Nm]	21
Air consumption	[m ³ min ⁻¹]	6,7
Thrust cylinder travel	[mm]	755
Filtration	[µm]	50
Tool stop	[mm]	22 x 108
Weight	[kg]	44
Inside diameter of the supply hose	[mm]	Js 25
Inside diameter of the supply hose	[mm]	Js 13

THE PPP 300 PNEUMATIC DIRECT SAW

DESCRIPTION:

The PPP 300 pneumatic direct saw is used for cutting and dividing of materials in heavy duty operations. Saw oscillations are caused by a cam mechanism that is driven by a multi-plate motor.

The PPP 300 pneumatic direct saw does not contain any light metal alloys; therefore it can be used in the explosion danger environment.

The saw consists of the following basic parts:

- Body with the cam mechanism S/N: 0013 PD 1000
- Pneumatic motor with control S/N: 0013 PD 2000

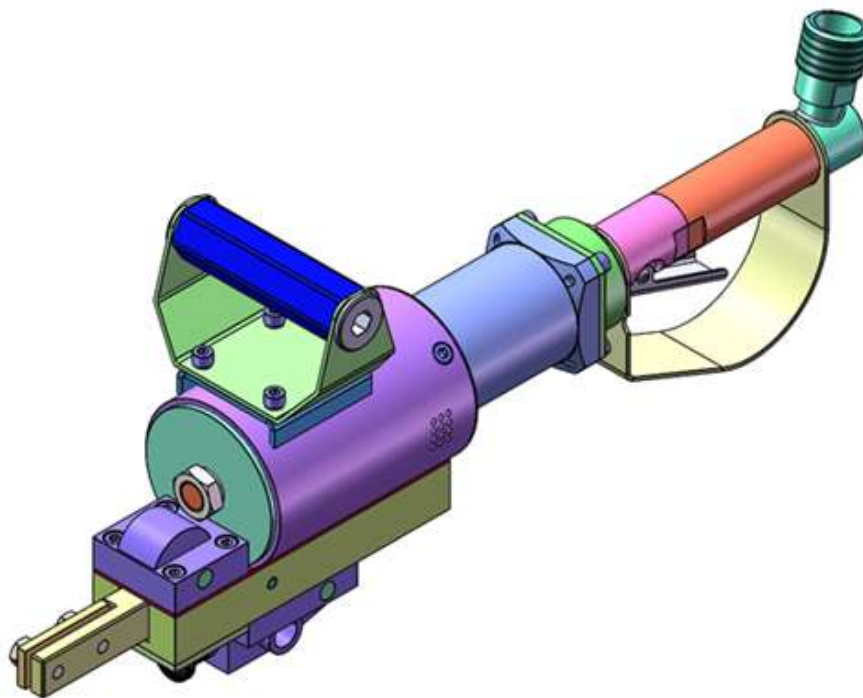

TECHNICAL PARAMETERS:

Operating pressure	[MPa]	0,4 – 0,6
Max. output	[kW]	1,1
Air consumption	[m ³ min ⁻¹]	1,2
Saw blade travel	[mm]	65
Filtration	[µm]	50
Number of oscillations	[min ⁻¹]	380
Weight	[kg]	10,8
Inside diameter of the supply hose	[mm]	Js 19

THE PPP 80 PNEUMATIC DIRECT SAWS

DESCRIPTION:

Pneumatic band saw PPP 80 is used for cutting and dividing materials in heavy production units. While sawing, there is no need to cool either the material or the saw band. The movement of the saw bend is transferred by means of four trolleys that are driven by plate engine with control. It is possible to use the saw as a hand saw or to fix it in chain holder.

The pneumatic band saw PPP 80 does not contain alloys and can be used in environment with explosion risk.

- Planetary transmission
- Pneumatic motor with control
- Planetary transmission

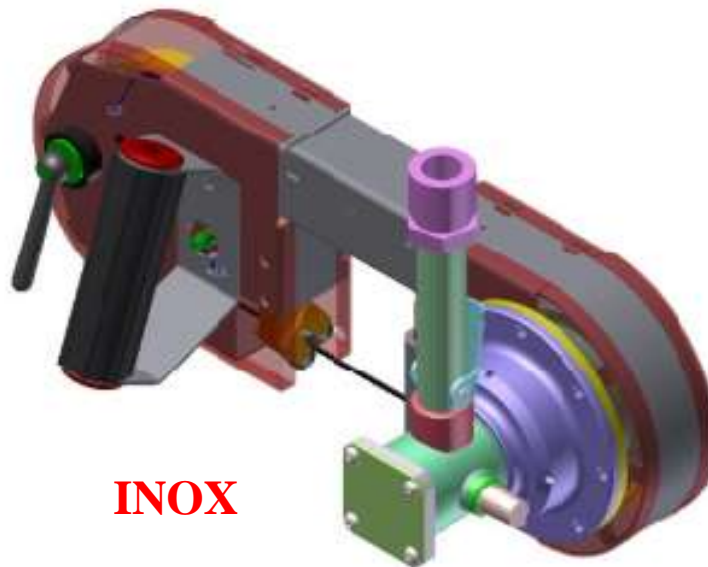

TECHNICAL PARAMETERS:

Operating pressure	[MPa]	0,4 – 0,6
Max. output	[kW]	0,7
Air consumption	[m ³ min ⁻¹]	0,9
Dimensions of cut material	[mm]	80 x 80
Filtration	[µm]	50
Band speed	[m/min ⁻¹]	65
Weight	[kg]	8,2
Saw chain attachment		Not supplied
Inside diameter of the supply hose	[mm]	Js 10

THE PPP 120, PPP 160 AND PPP 180 PNEUMATIC DIRECT SAWS

DESCRIPTION:

The PPP 120, PPP 160 and PPP 180 pneumatic direct saws are used for cutting and dividing of materials in heavy duty operations. The cut material or the saw band does not need to be cooled down during cutting. Movement of the saw band is transferred using two trolleys that are operated by a multi-plate motor with control.

The pneumatic band saws of PPP type do not contain light metal alloys and therefore can be used in the explosive danger environment.

The saws consist of the following basic parts:

- Saw frame - stainless steel
- Pneumatic motor with control
- Planetary transmission

INOX

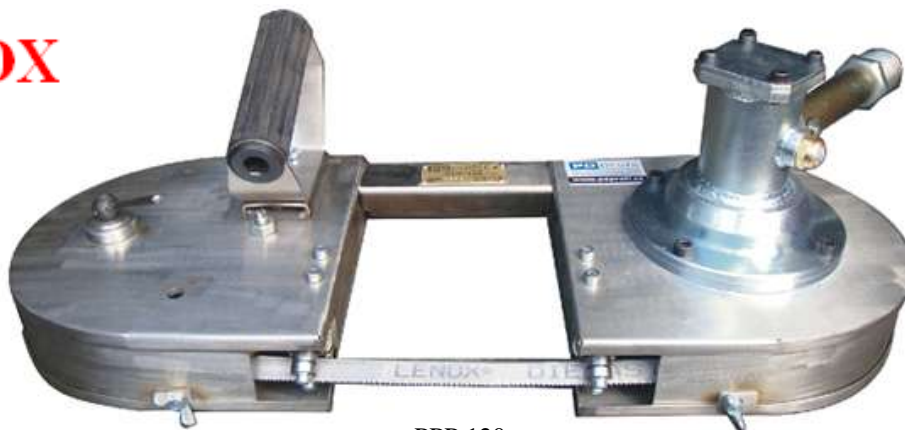

PPP 120

TECHNICAL PARAMETERS:

		PPP 120	PPP 160	PPP 180
Operating pressure	[MPa]	0,4 – 0,6		
Max. output	[kW]	0,7		0,8
Air consumption	[m ³ min ⁻¹]	0,9		
Dimensions of cut material	[mm]	120 x 150	160 x 150	180 x 180
Filtration	[µm]	50		
Band speed	[m/min ⁻¹]	65		
Weight	[kg]	10	10,2	13 + 2,5
Saw chain attachment		no		yes
Inside diameter of the supply hose	[mm]	Js 10		

THE PPP 270 PNEUMATIC DIRECT SAWS

DESCRIPTION:

Pneumatic band saw PPP 270 is used for cutting and dividing materials in heavy production units. While sawing, there is no need to cool either the material or the saw band. The movement of the saw bend is transferred by means of four trolleys that are driven by plate engine with control. It is possible to use the saw as a hand saw or to fix it in chain holder.

The pneumatic band saw PPP 270 does not contain alloys and can be used in environment with explosion risk.

INOX

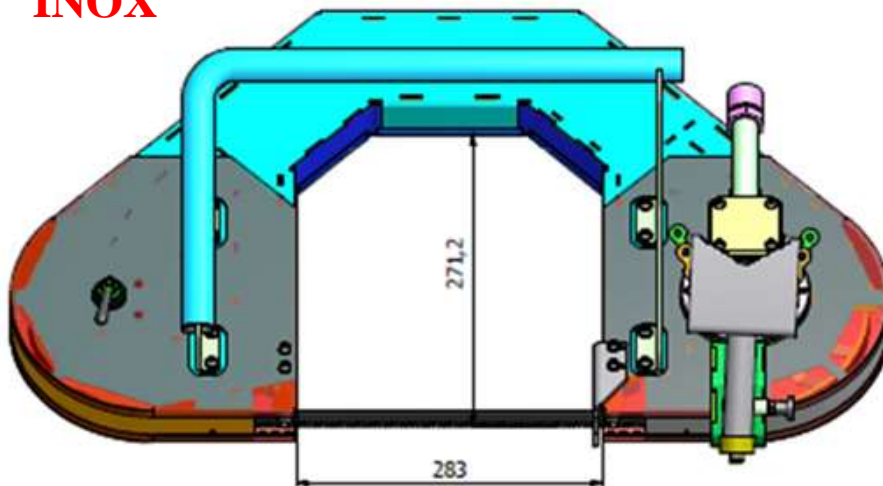

TECHNICAL PARAMETERS:

		PPP 270
Operating pressure	[MPa]	0,4 – 0,6
Max. output	[kW]	0,8
Air consumption	[m ³ min ⁻¹]	0,9
Dimensions of cut material	[mm]	283 x 271,2
Filtration	[µm]	50
Band speed	[m/min ⁻¹]	65
Weight	[kg]	20,5 + 3
Saw chain attachment		Not included
Inside diameter of the supply hose	[mm]	Js 10

THE PPR 40 PNEUMATIC CHAIN SAW

DESCRIPTION:

The PPR 40 pneumatic chain saw is intended for manual cutting of wood only. The saw bar length is 400mm.

The PPR 40 pneumatic chain saw consists of the control handle, body with a multi-plate motor, band brake, lubricating device, bar with a saw chain and top handle with cover. The saw meets requirements for use in mines (ATEX).



TECHNICAL PARAMETERS:

Operating pressure	[MPa]	0,4 – 0,6
Max. output	[kW]	1,5
Air consumption	[m ³ min ⁻¹]	3
Blade length	[mm]	400
Filtration	[µm]	50
Cutting speed	[m/s ⁻¹]	1,8
Weight	[kg]	10
Inside diameter of the supply hose	[mm]	Js 19

THE MP 20 PNEUMATIC BOOSTER (MULTIPLICATOR) PUMP

DESCRIPTION:

The MP 20 pneumatic booster (multiplier) pump is used for irrigation of coal seams by high pressure water in order to reduce environmental dust.

The MP 20 pneumatic booster (multiplier) pump is a single action, twin high pressure plunger pump. It is equipped by handles for easy handling at the workplace. The booster (multiplier) pump is made from stainless material and meets conditions for use in the I M2 explosive danger environment set by the EN 1127-2 standard.

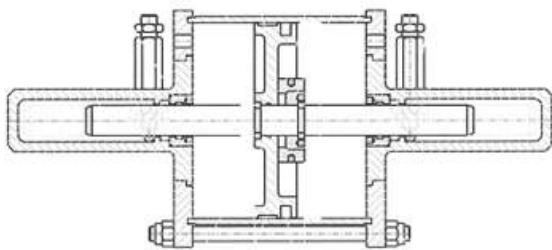

schématický výkres



TECHNICAL PARAMETERS:

Operating pressure	[MPa]	0,4 – 0,5
Water supply pressure	[MPa]	0,5
Water supply pressure at 0.4 MPa	[MPa]	16,4
Water supply pressure at 0.5 MPa	[MPa]	20,5
Air consumption	[m ³ h ⁻¹]	
Water flow at 0.5 MPa	[l.min ⁻¹]	7
Filtration	[µm]	50
Basic dimensions	[mm]	450 x 280 x 280
Weight	[kg]	37
Inside diameter of the supply hose	[mm]	Ø16mm

THE FV LINE AIR FILTERS

DESCRIPTION:

The FV line air filters are used for the filtration of pressure air for pneumatic tools and machines in heavy duty operations such as deep mines and foundries.

The FV 1" and FV 50 air filters consist of a steel pipe with a handle (or supports) of the cylindrical filter and a removable front. The FVO 1" filter is additionally equipped by lubrication to help oiling supplied pneumatic tools. Cleaning of the cylindrical filter is done by loosening of the central M16 nut and blowing off of the cylindrical filter by compressed air.

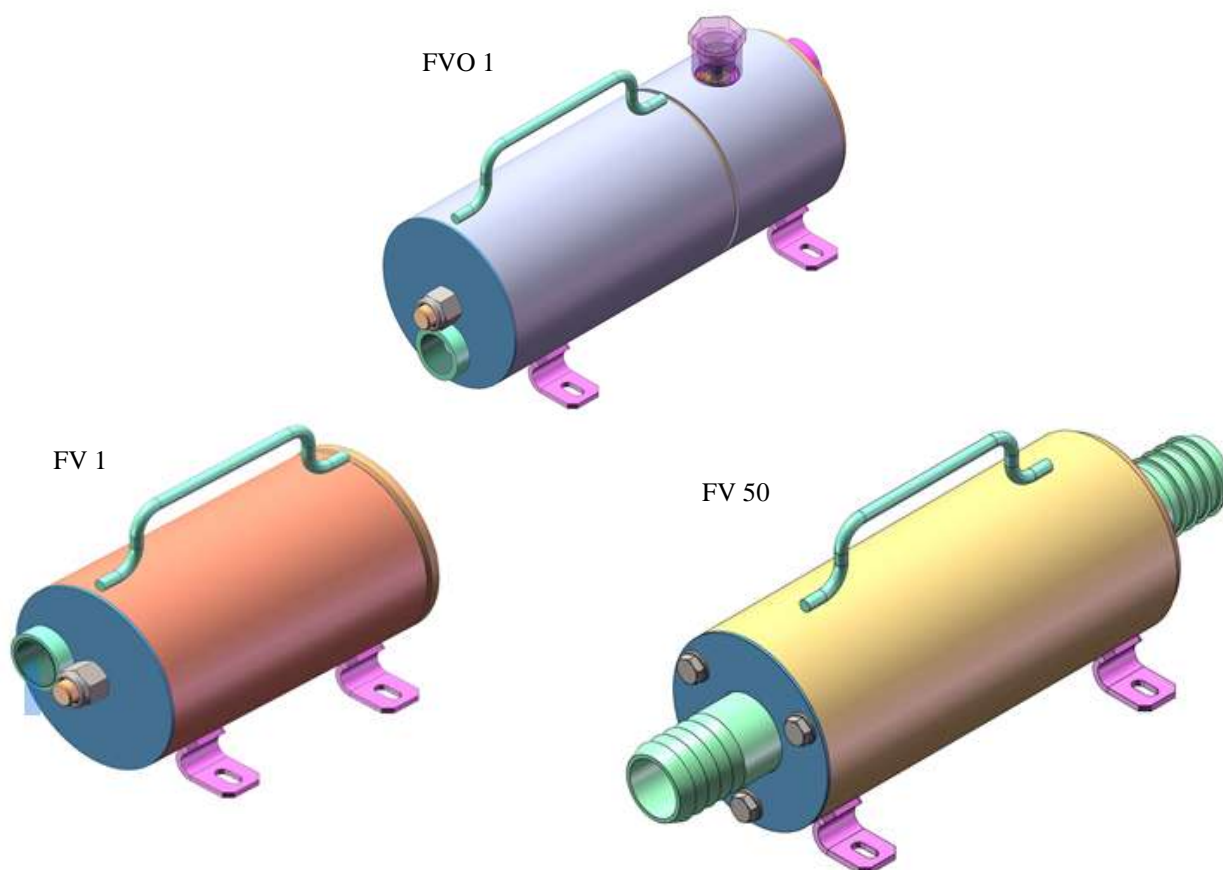

TECHNICAL PARAMETERS:

		FV 1"	FV 50	FVO 1"
Operating pressure	[MPa]		0,2 – 0,7	
DN		Závit 1"	50mm	Závit 1"
Filtration	[µm]		50, 100	
Basic dimensions	[mm]	Ø127x230	Ø127x453	Ø127x357
Weight	[kg]	4,5	7,3	7,8
Inside diameter of the supply hose	[mm]	Js 25	Js 50	Js 25

THE OVP 1 FLOAT WATER SEPARATOR

DESCRIPTION:

The OVP 1 float water separator is used for rough water filtration and separating of water droplets from pressure air for pneumatic tools and machines in heavy duty operations like deep mines, quarries, foundries, forges and others. The condensate is automatically drained after accumulation.

The OVP 1 float water separator consists of a pipe, two flanges, float mechanism and four bolts. Cleaning of the filter insert is done by reverse connection and flushing by pressure water.



TECHNICAL PARAMETERS:

Operating pressure	[MPa]	max 0,8
Input thread		1"
Output thread		2 x 3/4"
Filtration	[μ m]	500
Dimensions	[mm]	250 x 250 x 450
Weight	[kg]	31

THE CPV 1 SCREW PNEUMATIC PUMP

DESCRIPTION:

The CPV 1 screw pneumatic pump is used to pump clean or slightly polluted water with the particle size up to 5 mm or oil. It is intended for explosion atmosphere danger environment, where compressed air is available as a driving medium. This is primarily in underground parts and surface installations of deep mines with danger of methane and combustible dust. The pump is recommended to be used with the FVO 1" lubricating filter.

The CPV 1 pneumatic screw pump consists of:

- Pneumatic multi-plate moto
- Screw pump
- Mechanical clutch

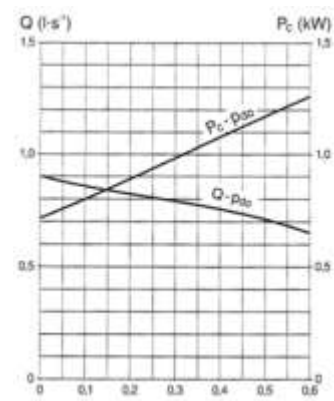

TECHNICAL PARAMETERS:

Air pressure	[MPa]	0.4 - 0.6
Flow through rate - max.	[l·sec ⁻¹]	0.7
Input	[kW]	Approx. 1.1
Filtration	[μm]	50
Air supply	[mm]	DN 25 (G 1")
Discharge branch	[mm]	DN 25 ("1")
Weight	[kg]	11.5

THE CPO 40 CENTRIFUGAL PNEUMATIC PUMP

DESCRIPTION:

The CPO 40 centrifugal pneumatic pump is used to pump clean or slightly polluted water with the particle size up to 5 mm. It is intended for explosion atmosphere danger environment, where pressure air is available as driving medium. This is primarily in underground parts and surface installations of deep mines with danger of methane and combustible dust. The pump is recommended to be used with the FVO 1“ lubricating filter.

The CPO 40 centrifugal pneumatic pump consists of:

- pneumatic multi-plate motor
- centrifugal pump with connecting pipe with shaft

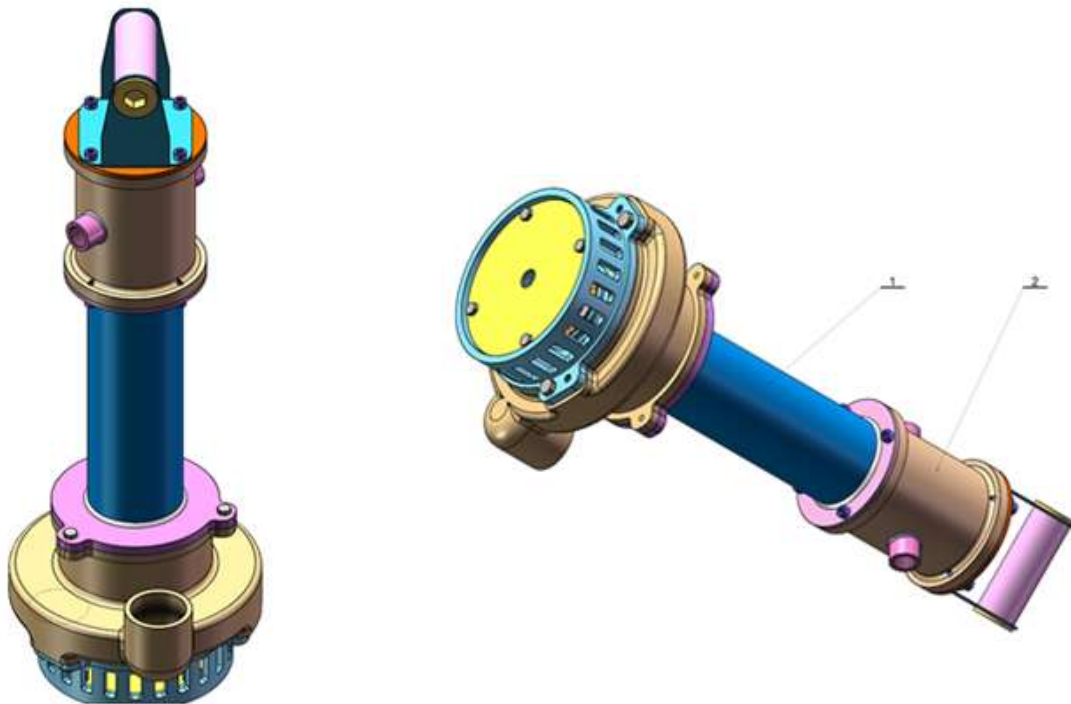

TECHNICAL PARAMETERS:

Air pressure	[MPa]	0,4 - 0,6
Flow through rate - max.	[l.sec ⁻¹]	6
Delivery height - max.	[m]	40
Input	[kW]	3
Filtration	[µm]	100
Air supply	[mm]	DN 20 (inside thread G 1“)
Discharge branch	[mm]	DN 50 (inside thread 2“)
Weight	[kg]	18

THE AUTOMATIC PUMP CONTROL PANEL PAOC 1

DESCRIPTION:

The pump automatic control panel (further called PAOC) is used for automatic starting and switching off of air pumps based on a level sensor signal.

Pressure air is brought to PAOC through the inner thread G 1“(Rd 32). The pressure air goes from the input to the power valve that is used to start or switch off the pump. The pump is connected to PAOC through the external RD 32 thread using hoses. The second branch that is used to evaluate the water level and to control the power valve is supplied through an integrated filter from the input. The sensed water column height is set by the manufacturer to 200 mm \pm 25 mm. The sensor is connected to PAOC by a hose with 6mm internal diameter.

Setting: On the pressure gauge (pos. 1) we will set the air pressure to approx. 0.15 – 0.2 MPa by the regulator knob (pos. 3). We will then set the sensor air supply by using the throttle screw (pos. 2). We need to screw the throttle screw (pos. 2) all the way in, and then by loosening it will set the air flow from the sensor (approx. 1 bubble per second).

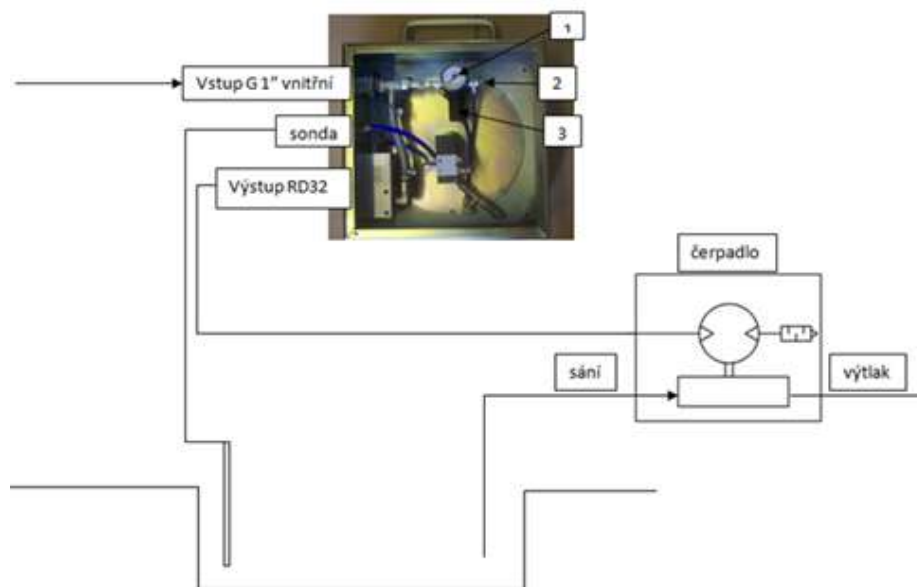

TECHNICAL PARAMETERS:

Operating pressure	[MPa]	0,4
Sensed level difference	[mm]	200 \pm 10%
Actuating pulse	[MPa]	0,15
Dimensions	[mm]	295x295x167
Weight	[kg]	16
Inside diameter of the supply hose	[mm]	Js 16

THE HSR 1650 HYDRAULIC IMPACT WRENCH

DESCRIPTION:

The HSR 1650 hydraulic impact wrench is used for loosening and tightening of nuts and bolts up to the M 30 size. The torque is created by a gear motor that transmits energy on the rotating hammer mechanism.

The HSR 1650 hydraulic impact wrench does not contain any light metal alloys; therefore it can be used in the explosion danger environment.

The wrench consists of three basic parts:

- Impact mechanism
- Hydraulic gear motor with control
- Starting lever

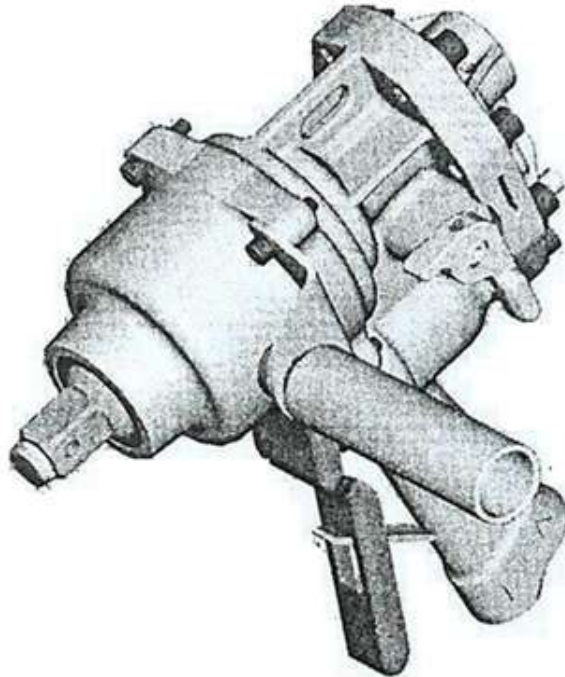

TECHNICAL PARAMETERS:

Number of impacts	min ⁻¹	1200
Maximum torque	Nm	1650
Operating pressure	MPa	7 – 14
Flow rate range	dm ³ .min ⁻¹	20 - 40
Driver size		1"
Filtration	μ	100
Weight	kg	9

HYDRAULIC IMPACT SCREWDRIVER HSR 1200

DESCRIPTION:

The HSR 1200 hydraulic impact screwdriver is used for loosening and tightening of nuts and bolts up to the M 30 size. The torque is created by an orbit motor that transmits energy on the rotating hammer mechanism.

The HSR 1200 hydraulic impact screwdriver does not contain any light metal alloys, therefore it can be used in the explosion danger environment.

The screwdriver consists of two basic parts:

- Impact mechanism
- Hydraulic orbit motor with control

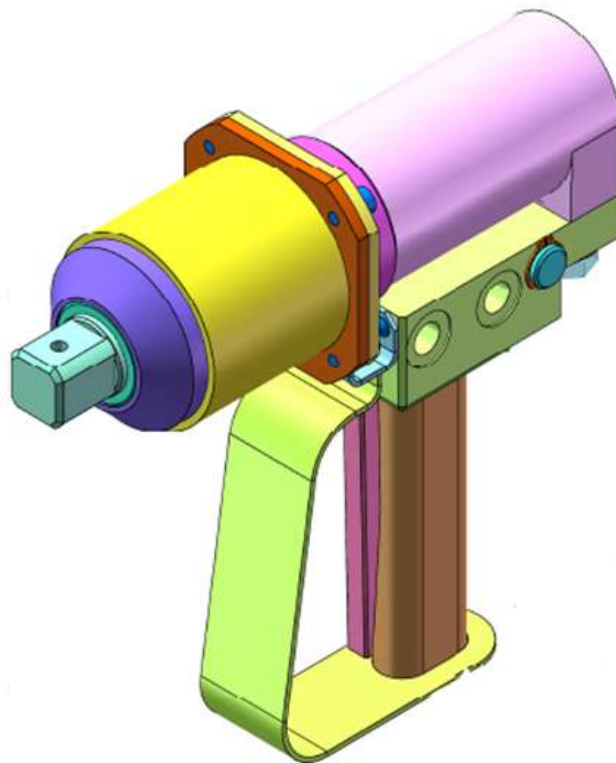

TECHNICAL PARAMETERS:

Number of impacts	min ⁻¹	1000±10%
Torque max	Nm	1200±10%
Hydraulic operating pressure	MPa	18
Flow through	dm ³ .min ⁻¹	25
Output square driver		3/4"
Weight	kg	7.2

THE ANTI-EXPLOSIVE VEN 42 SERIES EMULSION DRILLS

DESCRIPTION:

The anti-explosive VEN 42 series emulsion drill is used to drill into coal and medium-soft rocks using spiral drill rods with up to 42 mm diameter.

The anti-explosive VEN 42 emulsion drill consists of the pipe frame with control, emulsion motor and the mandrel for attachment of a drill rod.

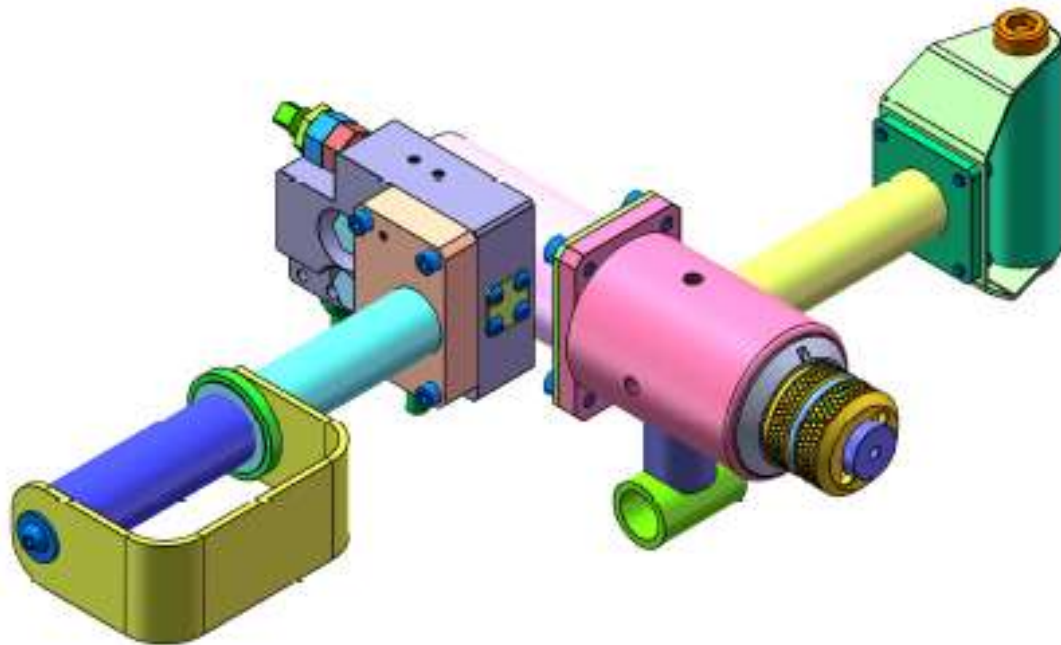

TECHNICAL PARAMETERS:

Max. operating pressure	[MPa]	32
Torque at 30MPa	[Mk]	75
Flow through rate at 400min ⁻¹	[dm ³ min ⁻¹]	9
Drilling diameter coal/steel	[mm]	48
Filtration	[µm]	100
Mandrel revolutions	[m/min ⁻¹]	100 - 1600
Weight	[kg]	approx. 8

THE PHP 300 HYDRAULIC DIRECT

DESCRIPTION:

The PHP 300 hydraulic direct saw is used for cutting and dividing of materials in heavy duty operations. Saw oscillations are caused by a cam mechanism that is driven by a multiple-plate motor.

The PHP 300 hydraulic direct saw does not contain any light metal alloys; therefore it can be used in the explosion danger environment.

The saw consists of the following basic parts:

- Body with the cam mechanism
- Hydraulic motor
- Handle with controls

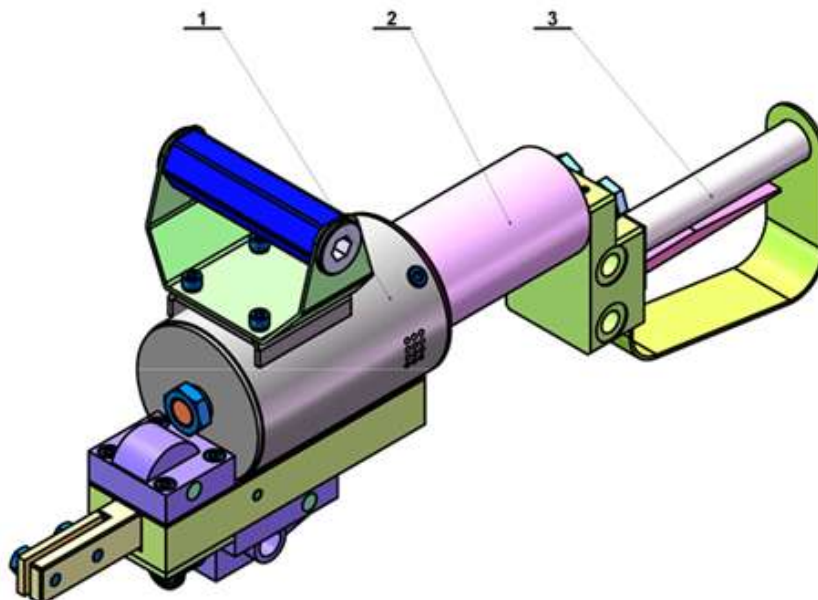

TECHNICAL PARAMETERS:

Operating pressure	[MPa]	7 - 20
Maximum output	[kW]	2
Flow through amount of oil	[l/min ⁻¹]	9 - 18
Dimensions of cut material	[mm]	300
Filtration	[µm]	25
Number of oscillations	[min-1]	250
Weight (saw + attachment)	[kg]	12,5
Saw blade travel	[mm]	65

HYDRAULIC BAND SAW PHP 80

DESCRIPTION:

The PHP 80 hydraulic band saw is used for cutting and dividing of materials in heavy duty operations. The saw band or cut material do not need to be cooled while sawing. The saw band movement is transferred using two pulleys that are driven by a hydraulic motor with control.

The hydraulic band saw PPP 80 does not contain light metal alloys and therefore can be used in the explosive danger environment.

The saw consists of the following basic parts:

- Saw frame - stainless steel
- Hydraulic motor with control
- Planetary transmission

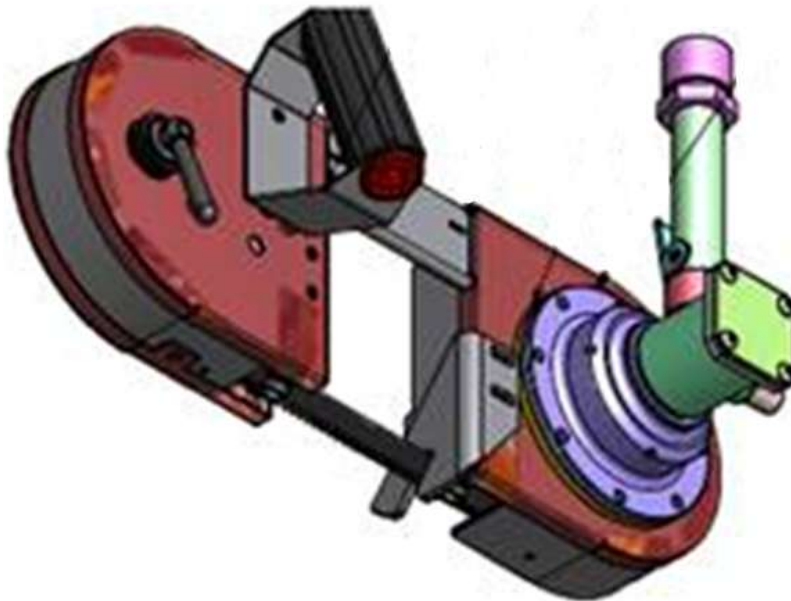

TECHNICAL PARAMETERS:

Operating pressure	[MPa]	7 - 20
Maximum output	[kW]	2
Flow through amount of oil	[l/min ⁻¹]	9 - 18
Dimensions of cut material	[mm]	80 x 80
Filtration	[μm]	25
Band speed	[m/min ⁻¹]	65
Weight (saw + attachment)	[kg]	9
Inside diameter of the supply hose	[mm]	10

THE PHP 120 AND PHP 180 HYDRAULIC BAND SAWS

DESCRIPTION:

The PHP 120 and PHP 180 hydraulic band saws are used to saw and divide materials in heavy duty operations. The saw band or cut material do not need to be cooled while sawing. The saw band movement is transferred using two pulleys that are driven by a hydraulic motor with control.

The pneumatic band saws of PHP type do not contain light metal alloys and therefore can be used in the explosive danger environment.

The saws consist of the following basic parts:

- Saw frame - stainless steel
- Hydraulic motor with control
- Planetary transmission

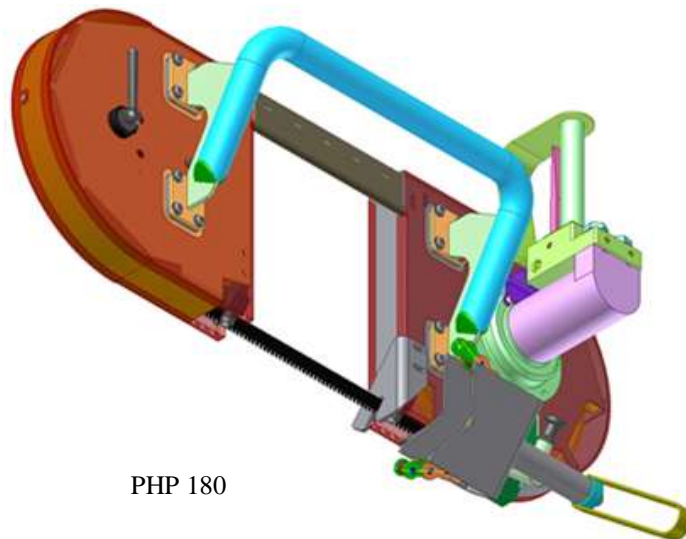

PHP 180

TECHNICAL PARAMETERS:

		PHP 120	PHP 160	PHP 180
Operating pressure	[MPa]		7 - 20	
Max. output	[kW]		2	
Flow through amount of oil	[l/min ⁻¹]		9 - 18	
Dimensions of cut material	[mm]	120 x 150	160 x 150	180 x 180
Filtration	[μm]		25	
Band speed	[m/min ⁻¹]		65	
Weight	[kg]	10,8	11	14,8 + 2,5
Connection of the hydraul. system	[mm]		10	

THE PHP 270 HYDRAULIC BAND SAWS

DESCRIPTION:

The PHP 270 hydraulic band saws are used to saw and divide materials in heavy duty operations. The saw band or cut material do not need to be cooled while sawing. The saw band movement is transferred using two pulleys that are driven by a hydraulic motor with control.

The hydraulic band saws of PHP type do not contain light metal alloys and therefore can be used in the explosive danger environment.

The saws consist of the following basic parts:

- Saw frame - stainless steel
- Hydraulic motor with control
- Planetary transmission

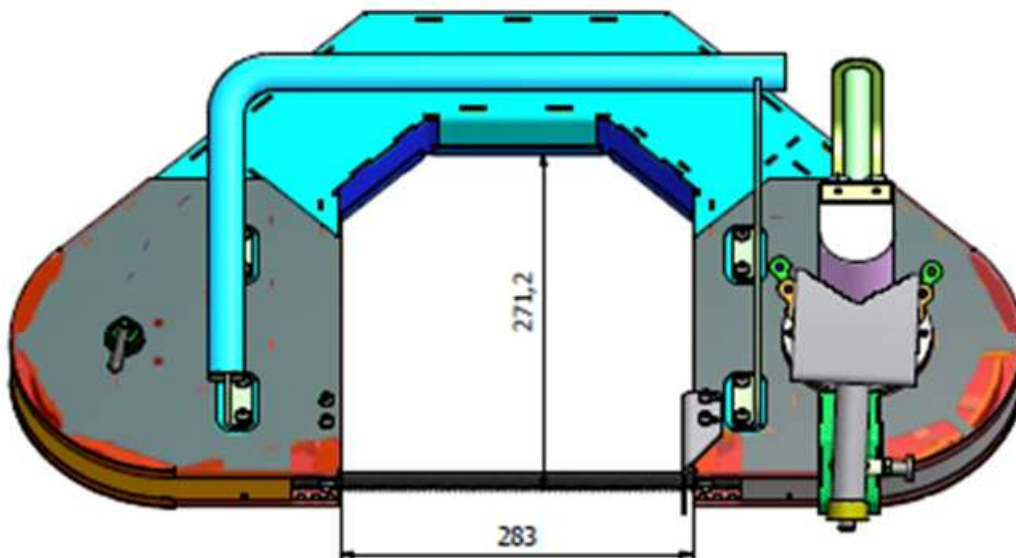

TECHNICAL PARAMETERS:

Operating pressure	[MPa]	7 - 20
Max. output	[kW]	2
Flow through amount of oil	[l/min ⁻¹]	9 - 18
Dimensions of cut material	[mm]	280 x 270
Filtration	[µm]	25
Band speed	[m/min ⁻¹]	65
Weight	[kg]	22 + 3
Connection of the hydraul. system	[mm]	10

HYDRAULIC HAMMER LH 11

DESCRIPTION:

The LH11 is a high performance light hydraulic jackhammer that is used for breaking down of concrete, bricks, walls, rocks, asphalt and other demolition a jackhammer type of work.

The LH11 is equipped by the closed “D” type handle that allows comfortable use in the vertical and horizontal positions. The “D” shape handle is provided with a special polyurethane coating to increase work comfort and also spring-cushioned to reduce vibrations.



TECHNICAL PARAMETERS:

Weight	kg	13,8
Number of impacts	Hz	40
Vibration	m/s ²	10,1
Volume speed of hydraulic fluid	l/min	18-22
Operating volume speed of hydraulic fluid	l/min	20
Max. pressure of hydraulic fluid	bar	160
Pressure range	bar	70-90
Max. tolerated back pressure of hydraulic fluid	bar	10
Guaranteed level of acoustic output	dB	107
Recommended inlet hoses	mm	<15 Js – 1/2 SAE 100R1
Tool stop	mm	#22 x 82 mm (7/8 x 3“ 1/4)

THE OKH 1 RAIL BENDER

DESCRIPTION:

The OKH 1 hydraulic rail bender is a device that is used for bending of profile Xa rails to required angles or for bending of other profiles that are specified in the table. The bending is done by a hydraulic cylinder driven by the AHR 70-1 manual hydraulic pump.

The bender consists of a single action hydraulic cylinder with return spring and replaceable restraint, frame with attachments and replaceable tensional shackles. The bender is attached to the AHR 70-1 manual pump by a 2m long hydraulic hose.

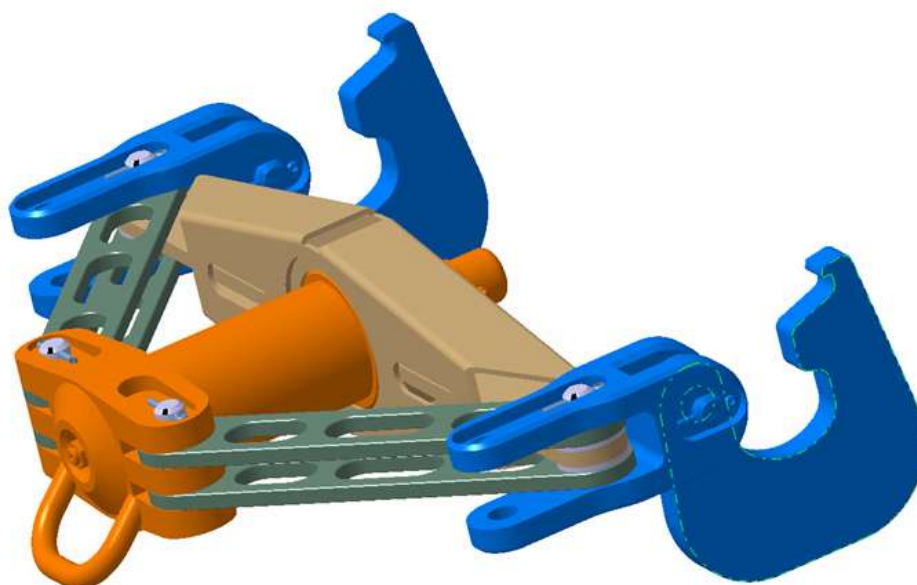

TECHNICAL PARAMETERS:

Maximum operational pressure	[MPa]	70
Maximum bending strength	[kN]	320
Travel of working cylinder	[mm]	150
Max. bending profile module at max. slip limit of bent material $R_e = 314$ MPa	[cm ³]	32
Bent profiles		Rails: Xa; 115/24; 93/18
Bent profiles		I and U profiles to the max. height of 160
Filtration	[μ m]	50
Basic dimensions	[mm]	870 x 440 x 180
Weight	[kg]	59
Weight with pump	[kg]	59 + 15
Connection openings		STEKO 10

THE VHS 1 – P2 HYDRAULIC DRILL RIG

DESCRIPTION:

The VHS 1 – P2 drill rig consists of a portable drill intended for drilling holes in rocks with consequent installation of bolting in deep mines, underground construction and other applications, and a separate control panel. The drill rig is powered by the AG 63/16Z hydraulic aggregate. With regard to its modular construction and low weight it is also suitable for operative use in hard to reach areas. It very simply allows changing the drill length and related depth of the hole and exchange of drilling tools in dependence on mining and geologic conditions.

The VHS 1 – P2 drill rig is designed for the group I, category M2 equipment according to the European Parliament and Council Directive 94/9/EC - ATEX and meets conditions for use in "dangerous atmospheric conditions 2" according to the EN 1127-2+A1 standard with concurrent meeting of valid national regulations of the operator.

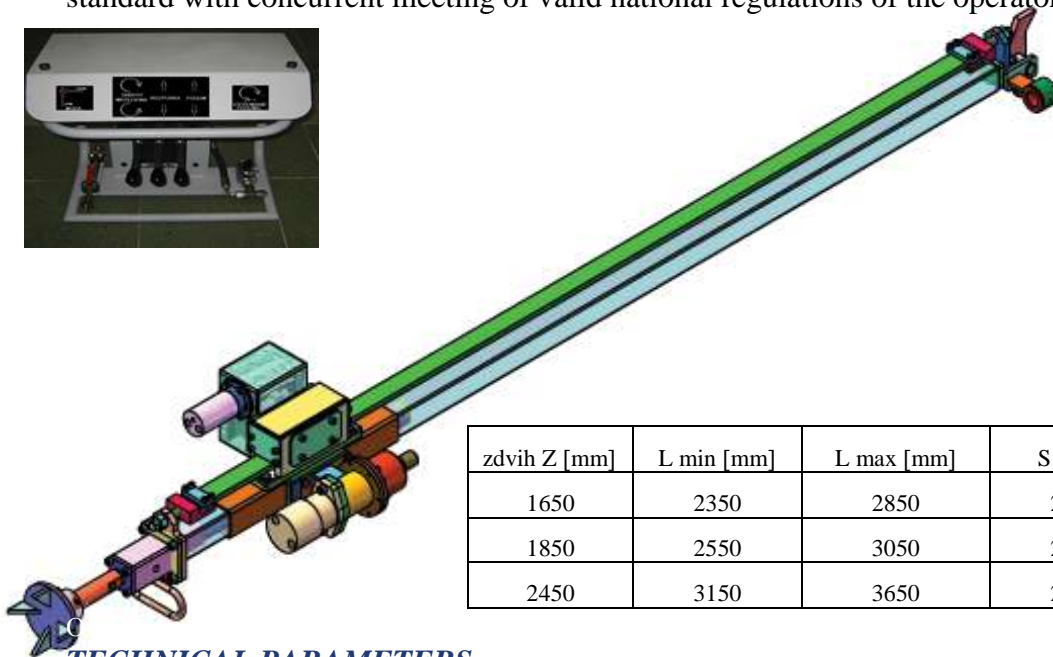

zdvih Z [mm]	L min [mm]	L max [mm]	S [mm]	V [mm]
1650	2350	2850	2000	1640
1850	2550	3050	2200	1840
2450	3150	3650	2440	2440

TECHNICAL PARAMETERS:

Pressure of hydraulic fluid	[MPa]	17
Water supply pressure	[MPa]	1,2
Maximum torque	[Nm]	440
Flow through amount of oil	[dm ³ min ⁻¹]	60
Thrust cylinder travel	[mm]	500
Filtration	[µm]	50
Tool stop	[mm]	22 x 108
Weight drill	[kg]	57
Weight of the control panel	[kg]	36
Min. length of the drill	[mm]	1900

PORTABLE DRILL RIG VHS 1 – P1

DESCRIPTION:

The VHS 1-P1 portable drill rig is used to drill up to 260 mm holes in deep mine rocks. The drill rig is operated together with the control panel.

The VHS 1 – P1 drill rig is designed for the group I, category M2 equipment according to the European Parliament and Council Directive 94/9/EC - ATEX and meets conditions for use in “dangerous atmospheric conditions 2” according to the EN 1127-2+A1 standard with concurrent meeting of valid national regulations of the operator.

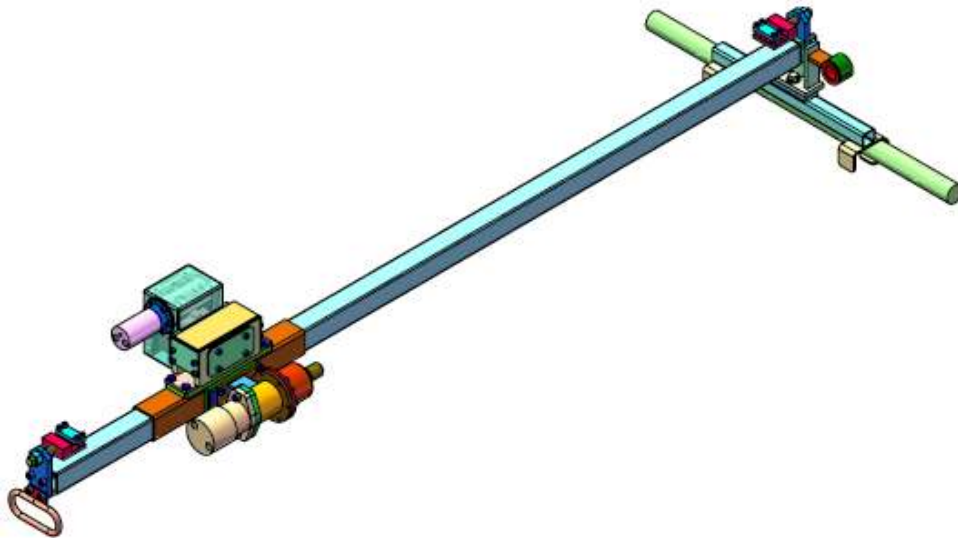

TECHNICAL PARAMETERS:

Work medium operation pressure	[MPa]	32
Operational water pressure	[MPa]	1,2
Maximum torque	[Nm]	170 - 440
Liquid flow rate at 300 rpm	[dm ³ min ⁻¹]	66
RPMs	[min ⁻¹]	290 – (700)
Drilling diameter	[mm]	up to 260 mm
Work medium		HFA emulsion, min. to 1.5%
Max. rise	[mm]	1 750
Filtration	[µm]	50
Travel speed w/out load	[ms ⁻¹]	0.1 – 0.2
Drill weight without special console	[kg]	65
Weight of the control panel	[kg]	36
Drill rods		CR 33.5

THE VHS 1 – P3 HYDRAULIC DRILL RIG

DESCRIPTION:

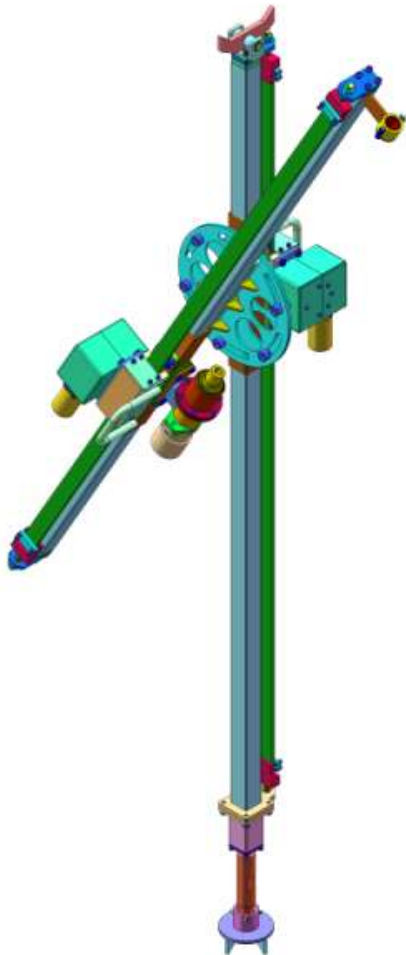

The VHS 1 – P3 drill rig consists of a portable drill intended for drilling holes in rocks with consequent installation of bolting in deep mines, underground construction and other applications, and a separate control panel. The drill rig is powered by the AG 63/16Z hydraulic aggregate. With regard to its modular construction and low weight it is also suitable for operative use in hard to reach areas. It very simply allows changing the drill length and related depth of the hole and exchange of drilling tools in dependence on mining and geologic conditions.

The VHS 1 – P3 drill rig is designed for the group I, category M2 equipment according to the European Parliament and Council Directive 94/9/EC - ATEX and meets conditions for use in "dangerous atmospheric conditions 2" according to the EN 1127-2+A1 standard with concurrent meeting of valid national regulations of the operator.

TECHNICAL PARAMETERS:

Pressure of hydraulic fluid	[MPa]	17
Water supply pressure	[MPa]	1,2
Maximum torque	[Nm]	440
Flow through amount of oil	[dm ³ min ⁻¹]	60
Thrust cylinder travel	[mm]	500
Filtration	[µm]	50
Tool stop	[mm]	22 x 108
Weight drill	[kg]	57
Weight of the control panel	[kg]	36
Min. length of the drill	[mm]	1900

THE SR 20 CHAIN CUTTER

DESCRIPTION:

The SR 20 chain cutter is a device that is used for cutting of high-strength chains up to the link diameter of 20mm with the maximum strength of used material 1100 MPa. The cutter is powered from its own pressure source (the AHR 70 manual/foot operated pump).

The SR 20 cutter consists of the following basic parts:

- Piston assembly 0054 PD 0001
- Cutter body 0054 PD 0003
- Back cover 0054 PD 0002

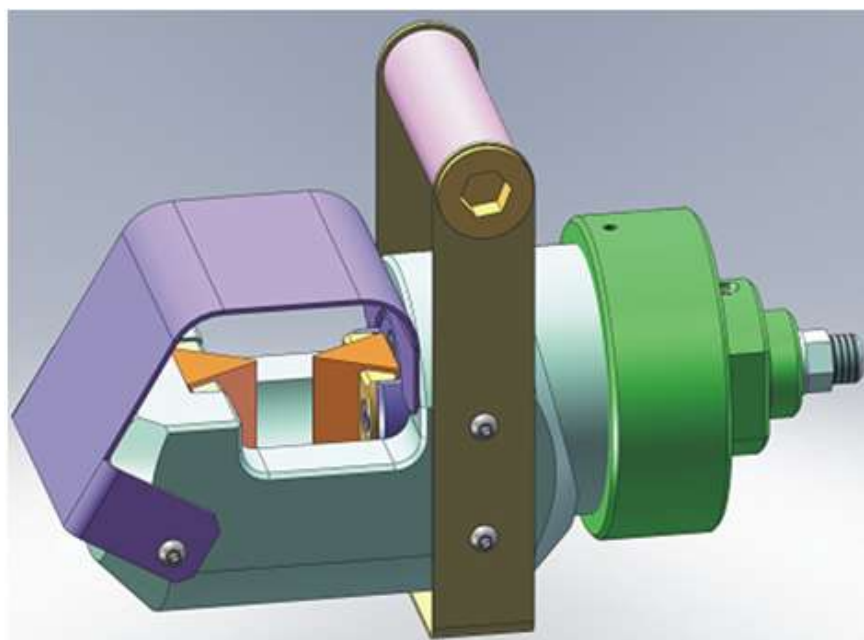

TECHNICAL PARAMETERS:

Max. pressure of hydraulic fluid	[MPa]	70
Maximum shearing force	[kN]	335
Maximum diameter of cut chain link	[mm]	20
Max. strength of cut chain link material	[MPa]	1100
Filtration	[µm]	50
Basic dimensions	[mm]	120 x 309
Weight	[kg]	12
Weight with the ratchet wrench – pump	[kg]	12 + 15
Inside diameter of the supply hose		STEKO 10

THE SR 42 CHAIN CUTTER

DESCRIPTION:

The SR 42 chain cutter is a device that is used for cutting of high-strength chains up to the link diameter of 42mm and 46mm flat chains with the maximum strength of used material 1200 MPa. The cutter is powered by water emulsion (central distribution 32MPa) or its own pressure source (the AHR 700 manual/foot operated pump). When it is powered from the central distribution, it is controlled by the control unit - three way valve that can be placed (for safety reasons) in any distance from the cutter.

The SR 42 cutter consists of the following basic parts:

- Piston assembly 0015 PD 3000
- Cylinder with cover 0015 PD 4000
- Shoe with cover 0015 PD 5000
- Complete return mechanism 0015 PD 6000

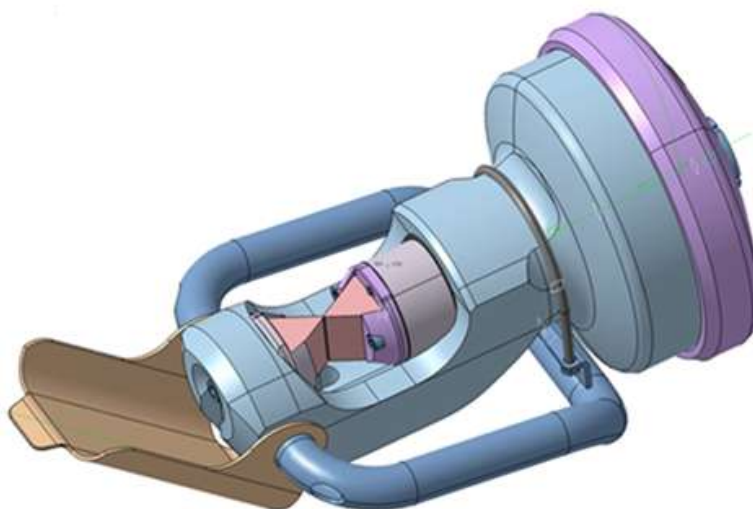

TECHNICAL PARAMETERS:

Max. pressure of hydraulic fluid	[MPa]	32
Maximum shearing force	[kN]	1200
Maximum diameter of cut chain link	[mm]	42
Maximum diameter of cut flat chain link	[mm]	46
Max. strength of cut chain link material	[MPa]	1200
Filtration	[μ m]	50
Basic dimensions	[mm]	290 x 595
Weight	[kg]	60
Weight with the ratchet wrench – pump	[kg]	60 + 9
Inside diameter of the supply hose		STEKO 10

HYDRAULIC CHAIN CUTTER SRH 42

DESCRIPTION:

The SRH 42 chain cutter is a device that is used for cutting of high-strength chains up to the link diameter of 42mm and 46mm flat chains with the maximum strength of used material 1200 MPa. The cutter is powered by a hydraulic hand/foot AHR 700 pump. Movement of the piston to the basic position is performed by a reverse mechanism with spring

The SRH 42 cutter consists of the following basic parts:

- Piston assembly
- Cylinder with cover
- Shoe with cover
- Complete return mechanism

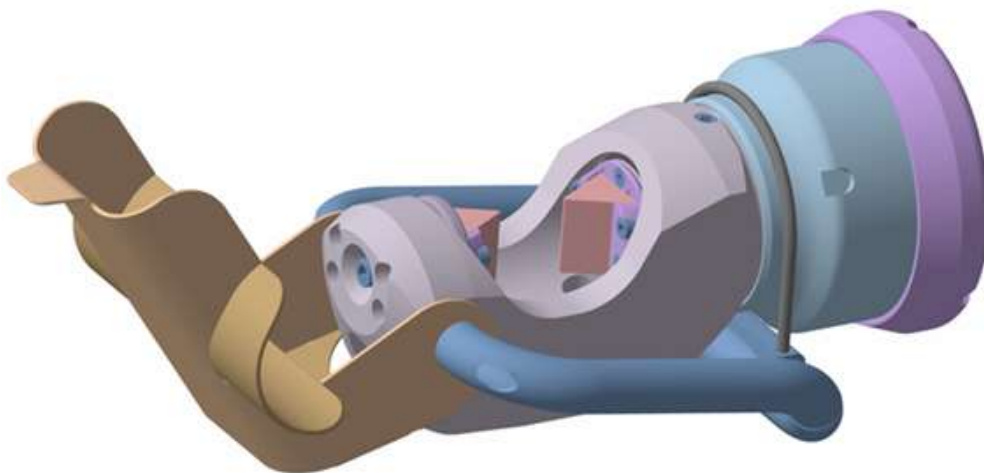

TECHNICAL PARAMETERS:

Maximum operational pressure	[MPa]	72
Maximum shearing force	[kN]	1370
Maximum diameter of cut chain link	[mm]	42
Maximum diameter of cut flat chain link	[mm]	46
Max. strength of cut chain link material	[MPa]	1200
Filtration	[µm]	50
Basic dimensions (w x l)	[mm]	293 x 446
Weight	[kg]	45
Weight with pump	[kg]	45 + 9
Connection openings		M18x1.5

THE RMH 30 AND RMR 30 NUT BREAKERS

DESCRIPTION:

The RMH 30 and RMR 30 nut breakers are devices that are used for breaking – cutting of M16 to M30 nuts. The RMH 30 hydraulic nut breaker is powered by pressure from the AHR 70 manual hydraulic pump. The RMR 30 manual nut breaker is manually operated using a ratchet wrench.

The RMH 30 and RMR 30 nut breakers consist of the following basic parts:

- Breaker body
- Breaking adapter with knife (opened, closed, ...)
- Ratchet wrench (RMR 30 only)

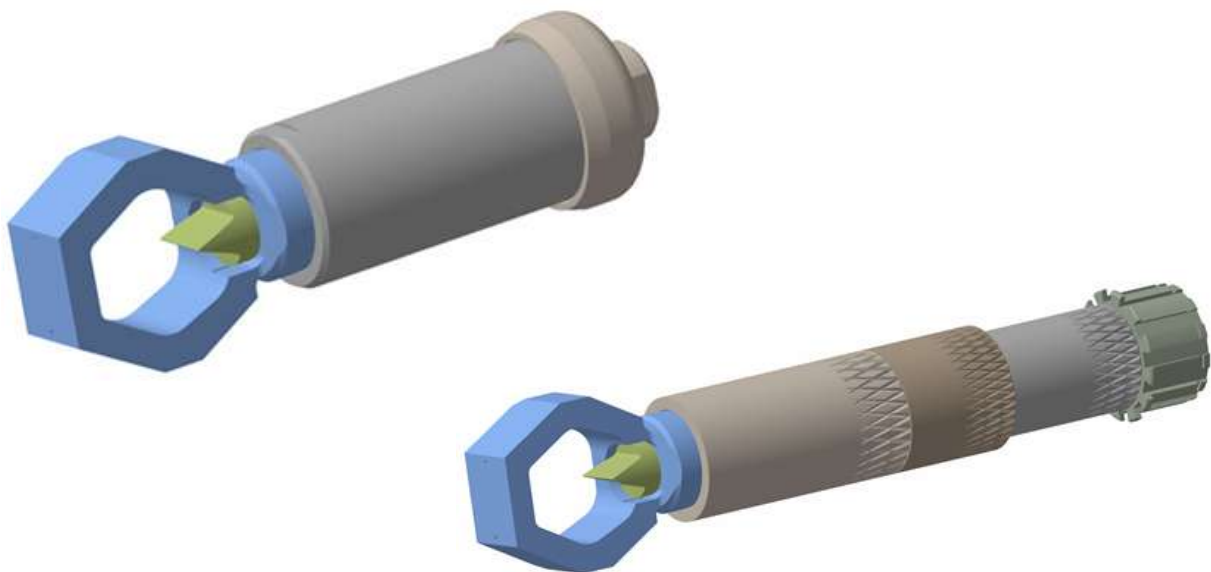

TECHNICAL PARAMETERS:

		RMR 30	RMH 30
Max. pressure of hydraulic fluid	[MPa]	-	70
Dimension of nuts to be cut	[mm]	M 16 – M 30	
Max. strength of nuts	[MPa]	600	
Filtration	[µm]	-	50
Basic dimensions	[mm]	90 x 390	90 x 300
Weight	[kg]	cca 7,5	cca 5
Inside diameter of the supply hose		-	STEKO 10

THE HYDRAULIC STUD CUTTER SSH 25

DESCRIPTION:

The hydraulic stud cutter SSH 25 is a device that is used to cut rope studs of up to 25 mm diameter. The SSH 25 hydraulic stud cutter is driven by pressure from the AHR 70 manual hydraulic pump.

The SSH 25 hydraulic stud cutter consists of the following basic parts:

- Cutter body
- Cutting head with knife

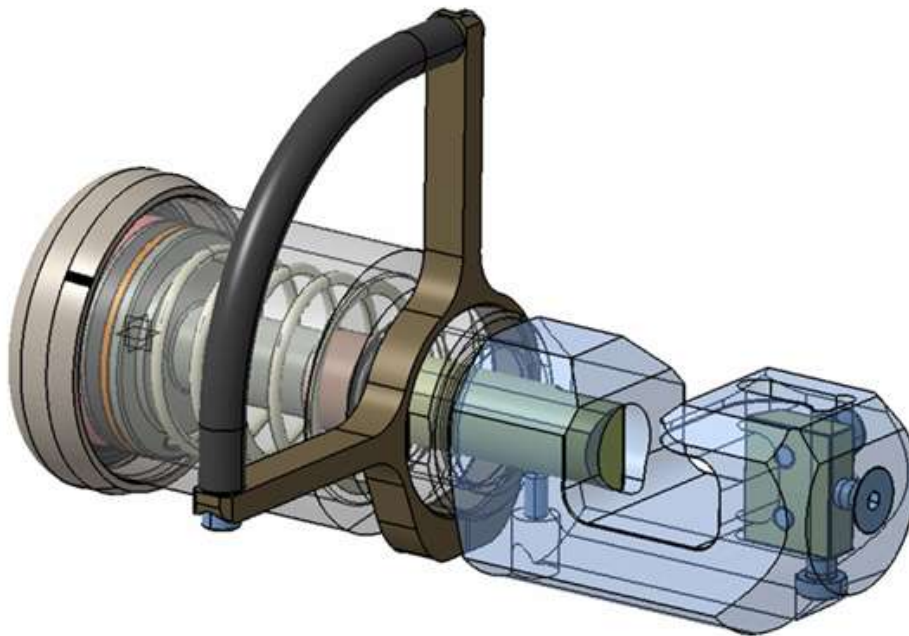

TECHNICAL PARAMETERS:

Maximum operational pressure	[MPa]	70
Maximum diameter of cut stud	[mm]	25
Maximum stud strength	[MPa]	1850
Filtration	[µm]	50
Basic dimensions (w x h x l)	[mm]	180 x 190 x 345
Weight	[kg]	approx. 14
Cutting force at 70MPa pressure	[kN]	300
Connection openings		½"

THE AHR 70-1, AHR 70-2 AND AHR 250-1 MANUAL HYDRAULIC AGGREGATES

DESCRIPTION:

The AHR 70 and ARH 250 manual hydraulic aggregates (further only aggregates) are intended for powering of hydraulic devices such as hydraulic cylinders, scissors, presses and so on. The aggregates consist of the tank, body, control lever and outlet screw connection. The AHR 70-2 type is additionally equipped by a pressure gauge and two outlet screw connections.

The AHR manual hydraulic aggregates do not contain light metal alloys and are approved for the explosive danger environments (EX I M2 c IIB 95C X and EX II 2 GD c IIB 95C according to the European standards 94/9/EC and 1999/92/EC – usually called ATEX).

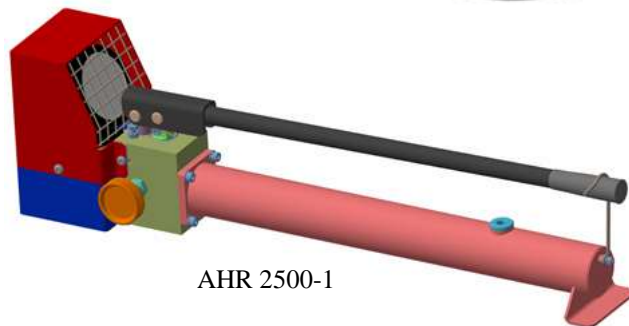

TECHNICAL PARAMETERS:

		AHR 700-2/1	AHR 700-2/2	AHR 2500-1
Max. pressure of hydraulic fluid	[MPa]	70	70	250
Working liquid		Operating liquid hydraulic oil for hydrostatic mechanisms with the viscosity 22, 32 or 46 mm ² .s ⁻¹ at 40°C		
Ambient temperature	[°C]	-10 až + 50		
Basic dimensions	[mm]			790x120x180
Tank volume	[l]	2,7	3	1,7
Weight	[kg]	15	17	20

THE AG-63/16Z HYDRAULIC AGGREGATE

DESCRIPTION:

The AG-63/16Z hydraulic aggregate is intended for powering of mining machinery and equipment. Additional effective cooling is applied for the VPS 01 drill rig operated under more demanding climatic conditions during longer use.

The AG-63/16Z hydraulic aggregate is designed for the group I, category M2 equipment according to the European Parliament and Council Directive 94/9/EC - ATEX and meets conditions for use in "dangerous atmospheric conditions 2" according to the EN 1127-2+A1 standard with concurrent meeting of valid national regulations of the operator.

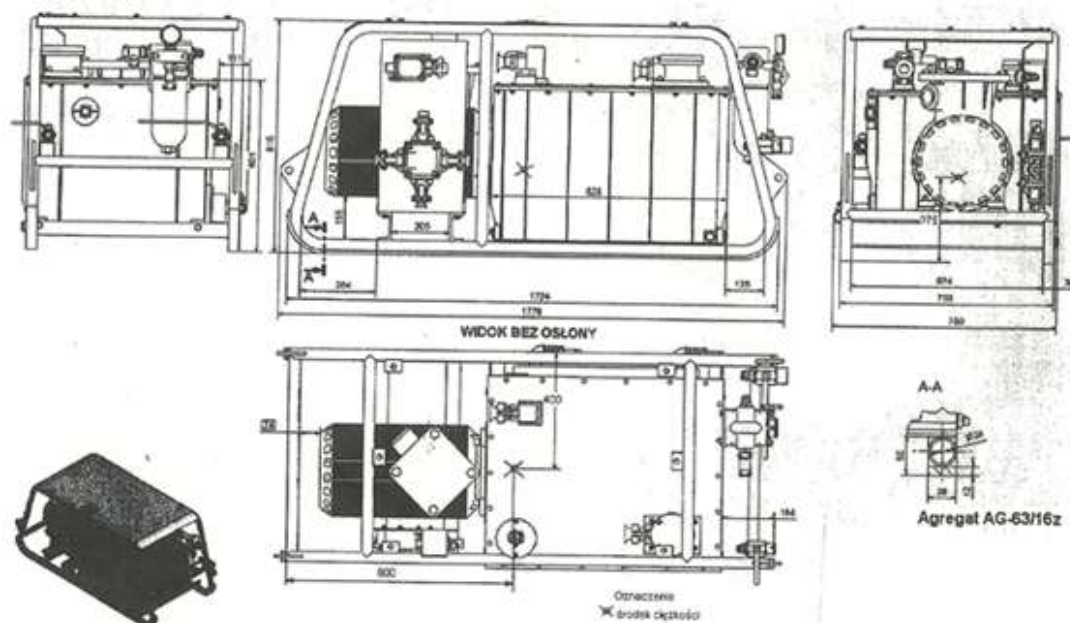

TECHNICAL PARAMETERS:

Pressure of hydraulic fluid	[MPa]	17
Tank volume	[dm ³]	200
Flow through amount of oil	[dm ³ min ⁻¹]	63
Working liquid		olej, HPL VG-46
Electric motor	[kW]	22
Electric motor voltage	[V]	500
Basic dimensions	[mm]	750x800x1780
Weight without oil	[kg]	550
Outlet of discharge branch	[mm]	20
Outlet of back branch	[mm]	25

THE NMR MANUAL TORQUE BOOSTER

DESCRIPTION:

The NMR manual torque booster (multiplier)s are used for loosening and tightening of bolt connections in the heavy industry. The tightening torque is caused by a ratchet wrench that transfers the torque to the outlet 1" driver using planetary gears. The exact setting of torque is done by a torque wrench.

The NMR manual torque boosters (multiplier) do not contain light metal alloys and are approved for the explosive danger environments (EX I M2 c IIB 95C X and EX II 2 GD c IIB 95C according to the new European standard 94/9/EC and the 1999/92/EC standard – usually called ATEX).



TECHNICAL PARAMETERS:

		NMR 15	NMR 20	NMR 25	NMR 35	NMR 40	NMR 15
Maximum torque	[Nm]	1 700	1 815	2 300	3 600	4 000	1 700
Gear ratio		1 : 4	1 : 12	1 : 10	1 : 14	1 : 15	1 : 4
Inlet driver	[mm]	3/4"					
Outlet driver	[mm]	1"	1"	1"	1"	1 1/2"	1 1/2"
Basic dimensions	[mm]	172 x 81	230 x 81	303 x 81	273 x 81	238 x 95	244 x 114
Weight	[kg]	3	5	6	5,5	7	9
Accessory		Stop block					

THE SRR 16 HAND CHAIN CUTTER

DESCRIPTION:

The SRR 16 hand chain cutter is used to cut chains and other profiles up to the material strength of 600MPa.

The SRR 16 hand chain cutter consists of the cutter body with a mechanical-hydraulic transfer, cutting head with knives and ratchet lever. The cutter is portable with a possibility of attachment to mine supports.

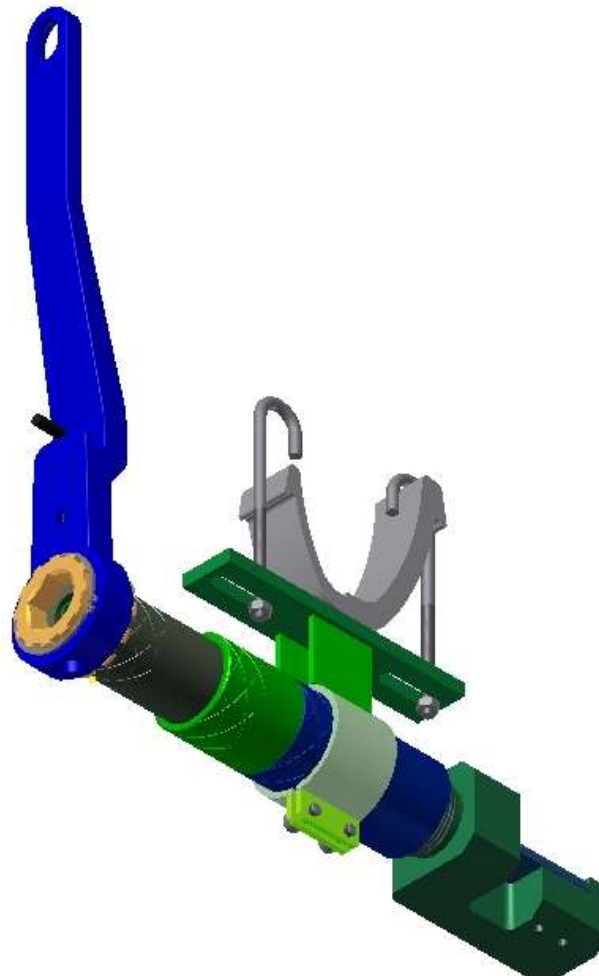

TECHNICAL PARAMETERS:

Max. pressure of hydraulic fluid	[MPa]	75
Dimension of chain to be cut	[mm]	0 – 16mm
Max. strength of cut chain link material	[MPa]	600
Basic dimensions	[mm]	90 x 410
Weight	[kg]	cca 10,5
Accessory		ratchet wrench

THE MK 10 HANDLING TROLLEY

DESCRIPTION:

The MK 10 handling trolley (further called only the trolley) is an air powered tool for manipulation with loads hanging on carts moving on the ZD 24 hanging track or its modifications for short distances. As opposed to the previous MK 8 type it has the reinforced load cart and increased spring pressure force to 29,2kN.

The trolley is equipped by a lever control hanging on supply hoses. It work on the principle of transfer of movement from driving wheels pushed against both sides of ZD 24 hanging track I profile vertical member.



TECHNICAL PARAMETERS:

Nominal traction	[N]	16 000	22 000
Brake force	[N]	20 000	24 000
Max. travel speed on level surface	[m.min. ⁻¹]	24	16
Installed power supply	[kW]	2 x 3,5	
Maximum path incline	[°]	± 20°	± 25°
Operating pressure	[MPa]	0,35-0,4	
Inside diameter of the supply hose	[mm]	32	
Used track		ZD 24	
Basic dimensions	[mm]	800 x 784 x 1126	
Weight	[kg]	390	
Max. weight of pulled load (with friction coefficient 0.1)	[kg]	Incline 0° 16 000	Incline 0° 22 000
		Incline 5° 8 566	Incline 5° 11 799
		Incline 10° 5 880	Incline 10° 8 084
		Incline 15° 4 502	Incline 15° 6 190
		Incline 20° 3 670	Incline 20° 5 046
		Incline 25° 4 286	

THE MK 16 HANDLING TROLLEY

DESCRIPTION:

The MK 16 handling trolley (further called only the trolley) is an air powered tool for manipulation with loads hanging on carts moving on the ZD 24 hanging track or its modifications for short distances. Compared to the previous type MK 10 has a separate brake jaw and increased braking force 25kN.

The trolley is equipped by a lever control hanging on supply hoses. It work on the principle of transfer of movement from driving wheels pushed against both sides of ZD 24 hanging track I profile vertical member.

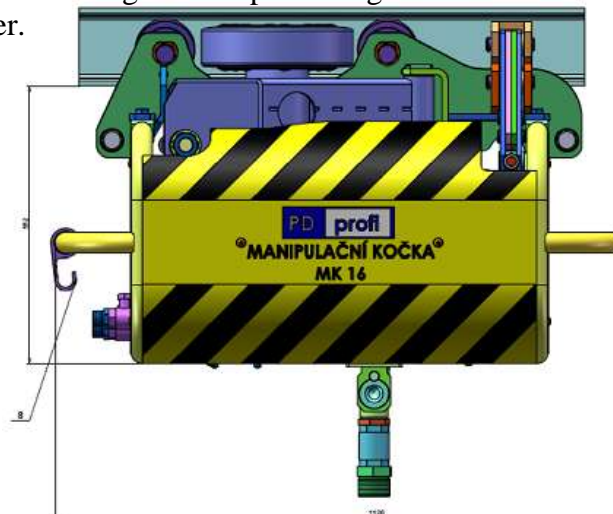

TECHNICAL PARAMETERS:

Nominal traction	[N]	16 000	22 000
Brake force	[N]	25 000	33 000
Max. travel speed on level surface	[m.min. ⁻¹]	24	16
Installed power supply	[kW]	2 x 3,5	
Maximum path incline	[°]	± 30°	
Operating pressure	[MPa]	0,35-0,4	
Inside diameter of the supply hose	[mm]	32	
Used track		ZD 24, ZD 24 A, ZD 24 B	
Basic dimensions	[mm]	800 x 784 x 1126	
Weight	[kg]	450	
Max. weight of pulled load (with friction coefficient 0.1)	[kg]	Incline 0° 16 000	Incline 0° 22 000
		Incline 5° 8 566	Incline 5° ... 11 799
		Incline 10° 5 880	Incline 10° 8 084
		Incline 15° 4 502	Incline 15° .. 6 190
		Incline 20° 3 670	Incline 20° ... 5 046
		Incline 25°	Incline 25° ... 4 286

THE TROLLEY WITH BRAKE VB 20

DESCRIPTION:

The trolley with brake VB 20 works as mechanically-pneumatic self-supporting brake on running cradles functioning as safety equipment in mine units. With its functionality, the trolley safeguards the equipment and its parts against unwanted travelling and provides for higher security when the maximum travelling speed is exceeded as it grips the track profile with its jaws. The construction design matches the requirements for mining equipment for environment with dangerous atmospheric conditions - 2 according to ČSN EN 1127-2 and legal requirements of Czech Republic and European Union. The operating incline of the traveling track is 0-25°, the maximum traveling speed 30 m.min⁻¹.

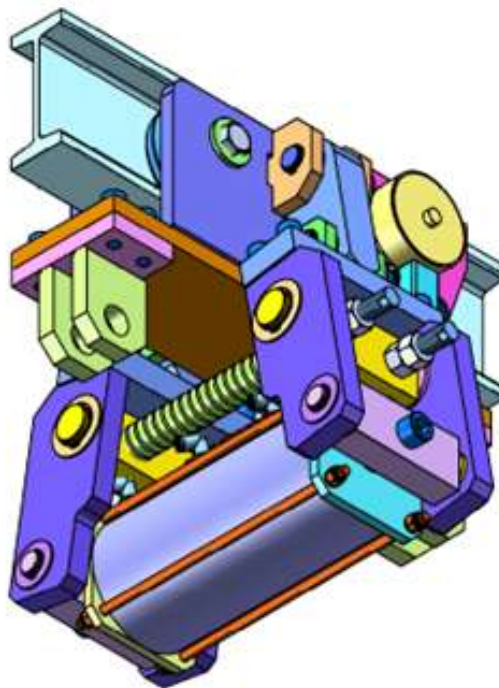

TECHNICAL PARAMETERS:

Brake force	[N]	20 000
Max. travel speed on level surface	[m.min. ⁻¹]	28
Maximum path incline	[°]	± 25°
Operational air pressure	[MPa]	0,35 - 0,4
Inside diameter of the supply hose	[mm]	10
Used track		ZD 24, ZD 24 A, ZD 24 B
Dimensions – h x w x l	[mm]	475 x 475 x 510
Weight of the trolley + cart	[kg]	200
Max. weight of pulled load	[kg]	15 000

THE MKH 16 – 16 000N HYDRAULIC HANDLING TROLLEY

DESCRIPTION:

The MK 16 handling trolley (further called only the trolley) is an air powered tool for manipulation with loads hanging on carts moving on the ZD 24 hanging track or its modifications for short distances. The trolley is supplied through the winding drum by 5 m long hydraulic hoses from the AG-63/16Z hydraulic aggregate.

The trolley is equipped by a lever control hanging on supply hoses. It work on the principle of transfer of movement from driving wheels pushed against both sides of ZD 24 hanging track I profile vertical member.

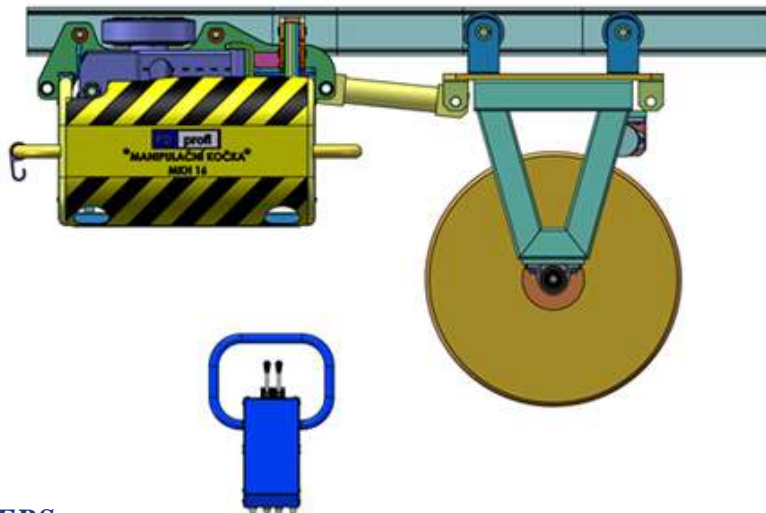

TECHNICAL PARAMETERS:

Nominal traction	[N]	16 000
Brake force	[N]	20 000 + 20 000
Max. travel speed on level surface	[m.min. ⁻¹]	24
Pressure medium		Oil 46mm ² /s
Maximum path incline	[°]	± 25°
Operational oil pressure	[MPa]	16
Inside diameter of the supply hose	[mm]	16
Used track		ZD 24, ZD 24 A, ZD 24 B
Dimensions – h x w x l	[mm]	800 x 800 x 950
Weight	[kg]	approx. 350 + 150
Max. weight of pulled load (with the friction coefficient 0.1)	[kg]	Incline 0° 16 000 Incline 5° 8 566 Incline 10° 5 880 Incline 15° 4 502 Incline 20° 3 670

THE HANGING WORK PLATFORM

DESCRIPTION:

The hanging work platform (hereinafter only platform) is an equipment moving on an “I” profile of the travelling track ZD 24 thanks to the handling trolley with pneumatic drive MK 16 or with hydraulic drive MKH 16. The platform is used for building, disassembling or controlling the travelling track.

The technological mining platform is used for equipment of mine galleries. It is basically a moving floor, hanging on two pendent trails, adjustable in vertical movement. From the platform, it is possible to do all different works in necessary height, transport instruments and build arches for mining supports. It is delivered in two different designs.

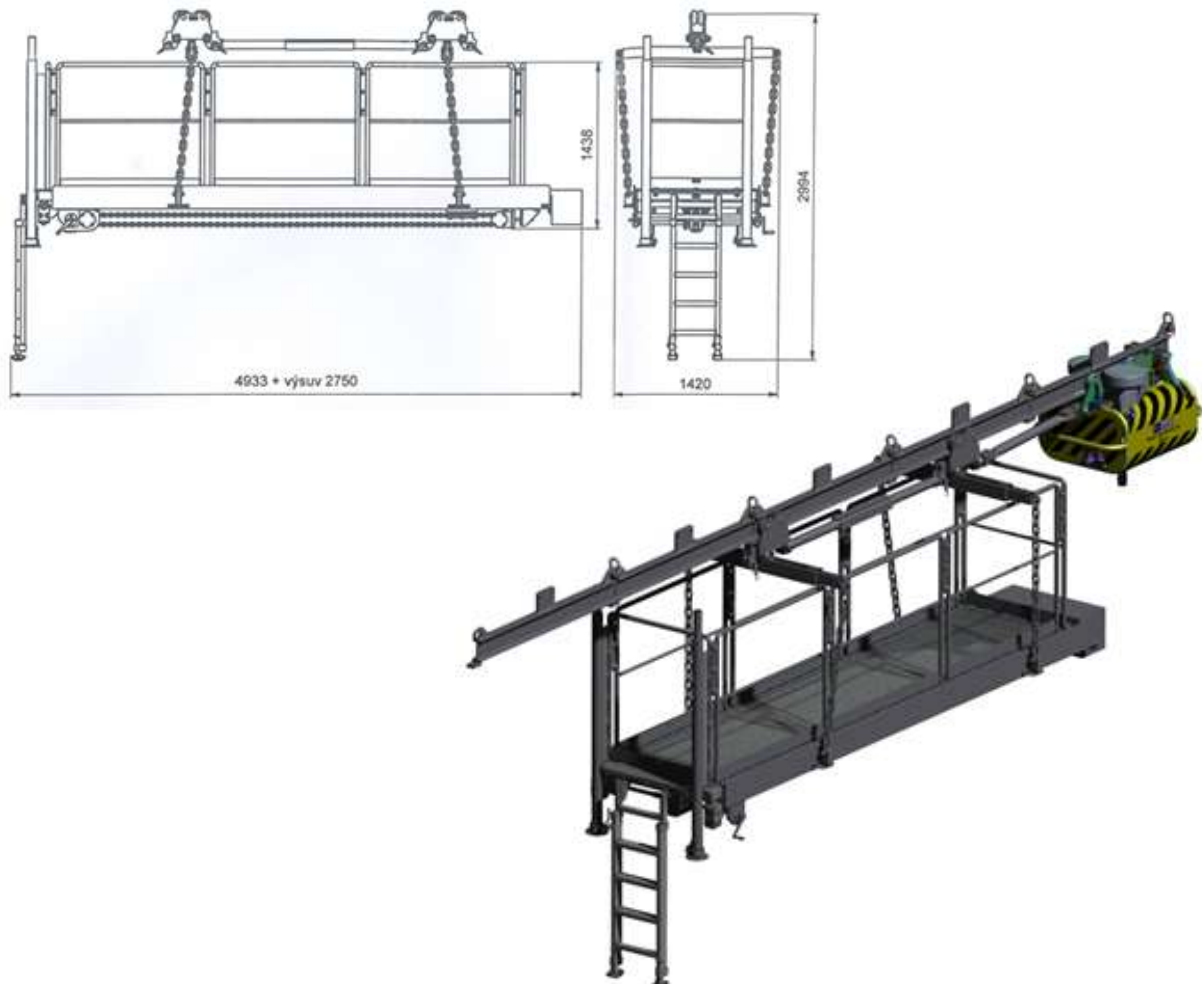

TECHNICAL PARAMETERS:

Loading	[kg]	400kg
Maximum path incline	[°]	± 18°
Used track		ZD 24, ZD 24 A, ZD 24 B
Dimensions – h x w x l	[mm]	4933(7683) x 1420 x 1438
Weight	[kg]	1875

THE MINE TECHNOLOGY PLATFORM

DESCRIPTION:

The mine technology platform is used to equip tunnels in mines. Basically it is a mobile floor that is hung on two hanging rails and adjustable in the vertical direction. Various operations at needed height, like transport of tools and material and setting of mining support arches, can be done from this platform. The platform is supplied in two versions: The P1 version is 4735 mm wide and it is intended for 30m² profiles. The P2 version is 3735 mm wide and it is intended for 20m² profiles. The platforms are pneumatically driven. Their movement along the rails is provided by two pneumatic MK10 trolleys, lifting of the platform is done by four mobile hoists. The platform pneumatic control system allows continuous regulation of all device functions. The maximum lengthwise incline of a mining work is allowed in the range of $\pm 12^\circ$, the maximum cross incline of the mine work is $\pm 5^\circ$. The platform is safeguarded against running away by two brake carts. The work lengthwise incline of the platform is limited by the range of $\pm 4^\circ$, the maximum allowed crosswise incline of the equipment is $\pm 3^\circ$. The platform in a working position can be horizontally and vertically fixed against movement.



TECHNICAL PARAMETERS:

Nominal traction force	[N]	32 000
Brake force	[N]	44 000
Max. travel speed on level surface	[m.min. ⁻¹]	24
Maximum path incline	[°]	$\pm 12^\circ$
Operational pressure	[MPa]	0,4
Inside diameter of the supply hose	[mm]	50
Used tracks		ZD 24, ZD 24 A, ZD 24 B D
Dimensions w x l	[mm]	4735 (3735) x 6686
Weight	[kg]	6400

THE Z 295 PNEUMATIC MANIPULATION DEVICE –1,6t, 3,2t, 5t

DESCRIPTION:

The Z 295 pneumatic manipulation device is used for vertical lifting and lowering of loads in places with pressure air supply.

The Z 295 pneumatic manipulation device consists of the following basic parts:

- Body with the hook assembly 1,6t, 3,2t, 5t
- Pneumatic motor MPP2, MPL 3

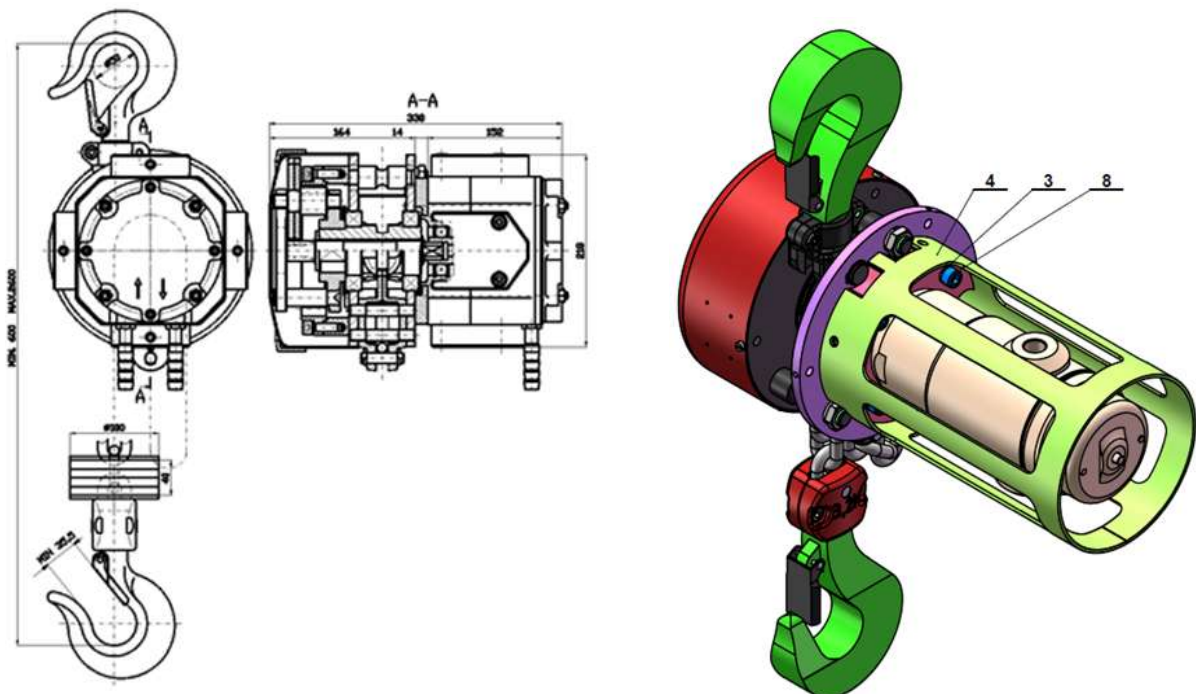

TECHNICAL PARAMETERS:

Loading	[t]	1,6	3,2	5
Load chain	[mm]	9 x 27	11 x 31	
Operating pressure	[MPa]	0,45-0,6		
Nominal motor output	[kW]	2	3	
Lifting speed	[m.mim ⁻¹]	1		0,5
Air consumption	[m ³ h ⁻¹]	37	144	
Filtration	[µm]	50		
Weight	[kg]	48	65	70
Inside diameter of the supply hose	[mm]	Ø 16	Ø 20	

THE ZMP 4/8t PNEUMATIC MANIPULATION DEVICE

DESCRIPTION:

The ZMP 4/8t pneumatic manipulation device is used for vertical lifting and lowering of loads in places with pressure air supply.

The ZMP 4/8t pneumatic manipulation device consists of the following basic parts:

- Body with the hook assembly 4/8t
- Pneumatic motor MPZ 3,5

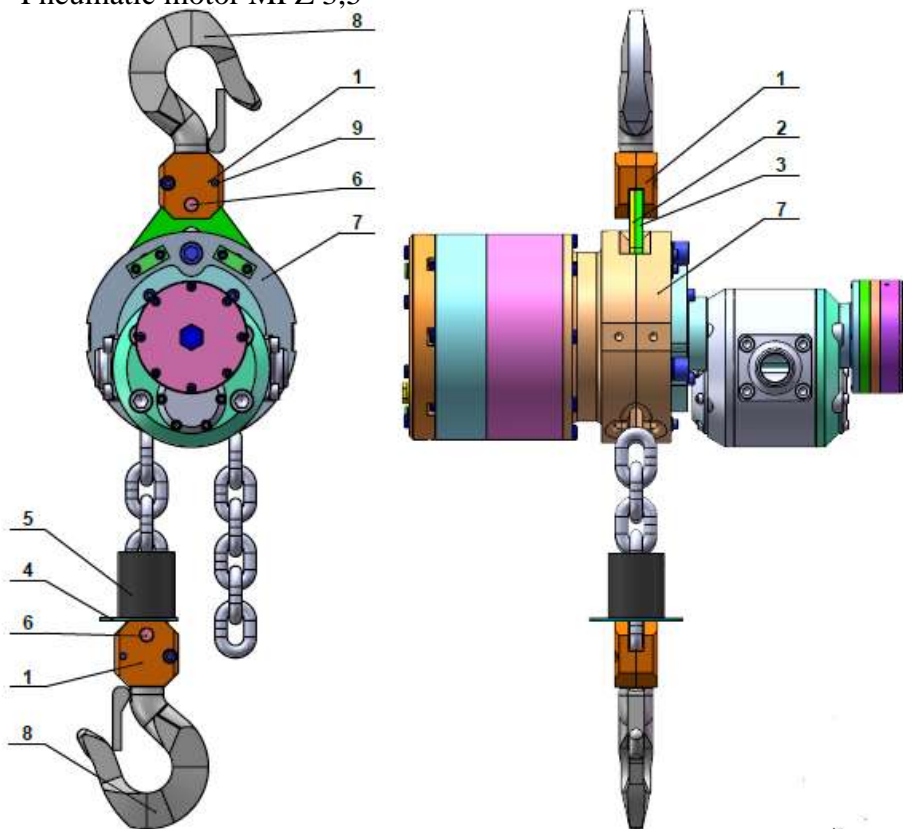

TECHNICAL PARAMETERS:

Loading	[t]	4/8
Load chain	[mm]	13 x 36
Operating pressure	[MPa]	0,45-0,6
Nominal motor output	[kW]	3,5
Lifting speed	[m.mim ⁻¹]	2,8/1,4
Air consumption	[m ³ h ⁻¹]	350
Filtration	[µm]	50
Weight	[kg]	110
Inside diameter of the supply hose	[mm]	Ø 25

THE ZMPP 3.2t/5t(6t) TRAVELLING PNEUMATIC MANIPULATION DEVICE

DESCRIPTION:

The ZMPP 3.2t/5t(6t) travelling pneumatic manipulation device is used for vertical lifting and lowering of loads on the ZD 24 hanging track in places with pressure air supply.

The ZMPP 3.2t/5t(6t) travelling pneumatic manipulation device consists of the following basic parts:

- Pneumatic piston motor MPP 3, version P1
- Pneumatic multi-plate motor MPL 3, version P2
- ZMPP 3.2t/5t(6t) load cart

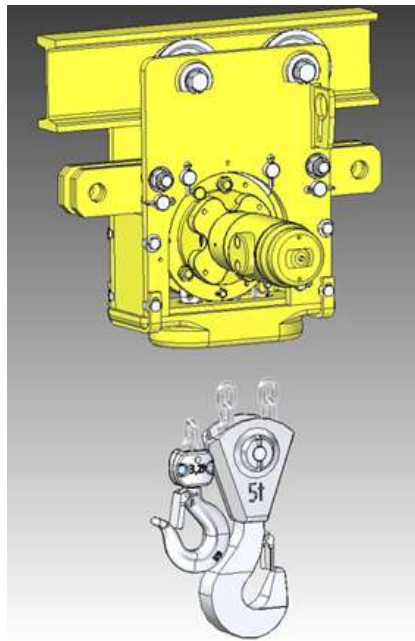

TECHNICAL PARAMETERS:

Loading	[t]	3,2	5 (6)
Load chain	[mm]	11x31	
Operating pressure	[MPa]	0,4 – 0,6	
Nominal motor output	[kW]	3	
Lifting speed	[m.mim ⁻¹]	1	0,5
Air consumption	[m ³ h ⁻¹]	144	
Filtration	[µm]	50	
Weight	[kg]	150	
Inside diameter of the supply hose	[mm]	Ø 16	

THE ZMRP 3,2t MANUAL TRAVELLING MANIPULATION DEVICE

DESCRIPTION:

The ZMRP 3,2t manual travelling manipulation device is used for vertical lifting and lowering of loads on the ZD 24 hanging track.

The ZMRP 3,2t manual travelling manipulation device consists of the following basic parts:

- ZMRP 3.2t manual tackle
- ZMRP 3.2t load cart

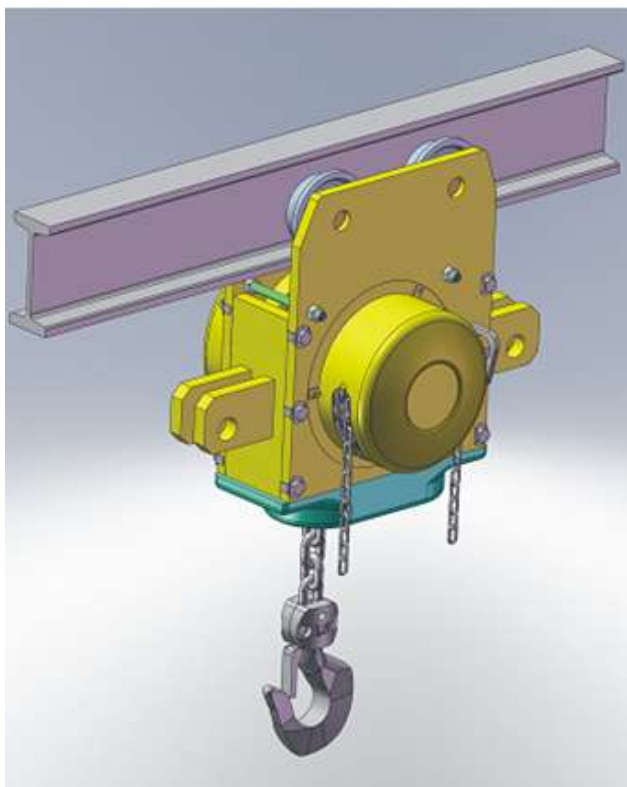

TECHNICAL PARAMETERS:

Loading	[t]	3,2
Load chain	[mm]	Ø 11 x 31
Control force	[N]	400
Hand chain	[mm]	Ø 4 x 20
Lifting speed	[m.mim ⁻¹]	0,29
Weight	[kg]	140

THE MZP 2x3.2t TRAVELLING MANIPULATION DEVICE

DESCRIPTION:

The **MZP 2x3.2t** travelling manipulation device is used for transport of material in mining operations along the ZD 24 type hanging track.

The **MZP 2x3.2t** travelling manipulation device consists of two ZMPP 3.2t manipulation devices connected by a connecting rod. MZP 2x3.2t can be pulled, for example, by the MK manipulation trolley connected by the connecting rod. Both ZMPP 3.2t manipulation devices are operated by the PO-2 control panel. The breaking cart is not a part of delivery.

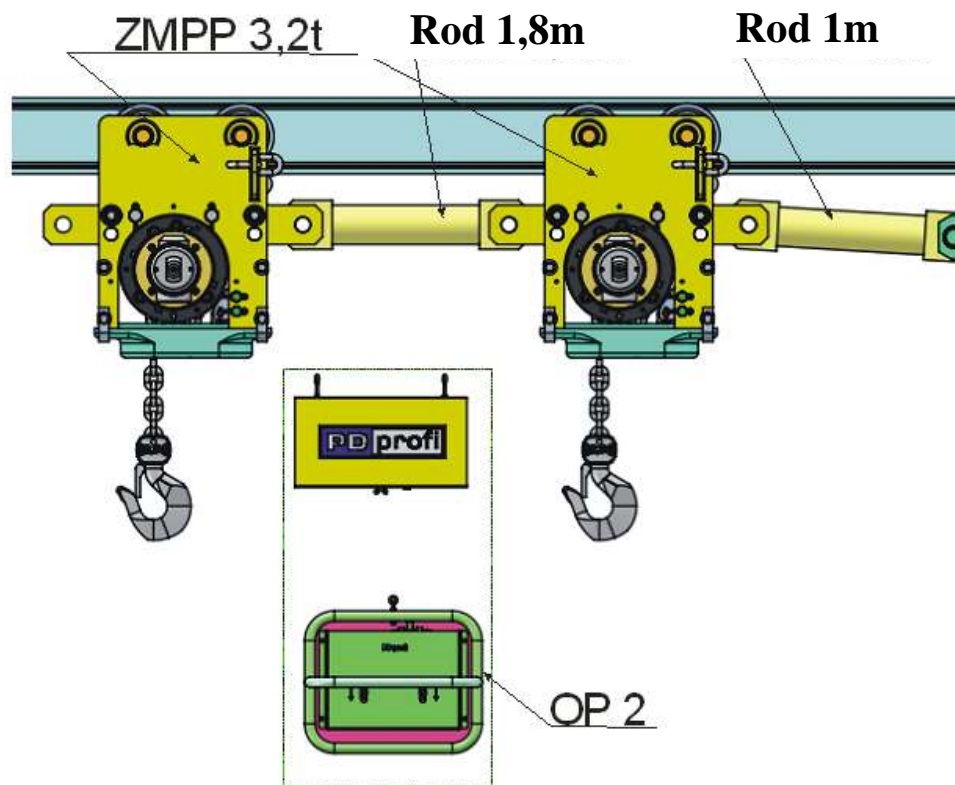

TECHNICAL PARAMETERS:

Maximum tension load MZP 2x3,2t	[kN]	62
Axis distance of hooks (hitches)	[mm]	as required
Elevation of hooks (basic)	[mm]	3000
Max. loading	[t]	2 x 3,2
Max. incline during lifting	[°]	±20
Operating pressure	[MPa]	0,4-0,6
Weight	[kg]	Approx. 320

THE MZP 2x3.2t/5t(6t) TRAVELLING MANIPULATION DEVICE

DESCRIPTION:

The **MZP 2x3.2t/5t(6t)** travelling manipulation device is used for transport of material in mining operations along the ZD 24 type hanging track.

The **MZP 2x3.2t/5t(6t)** travelling manipulation device consists of two ZMPP 3.2t/5t(6t) manipulation devices connected by a connecting rod. MZP 2x3.2t/5t(6t) can be pulled, for example, by the MK manipulation trolley connected by the connecting rod. Both ZMPP 3.2t/5t(6t) manipulation devices are operated by the PO-2 control panel. The breaking cart is not a part of delivery.

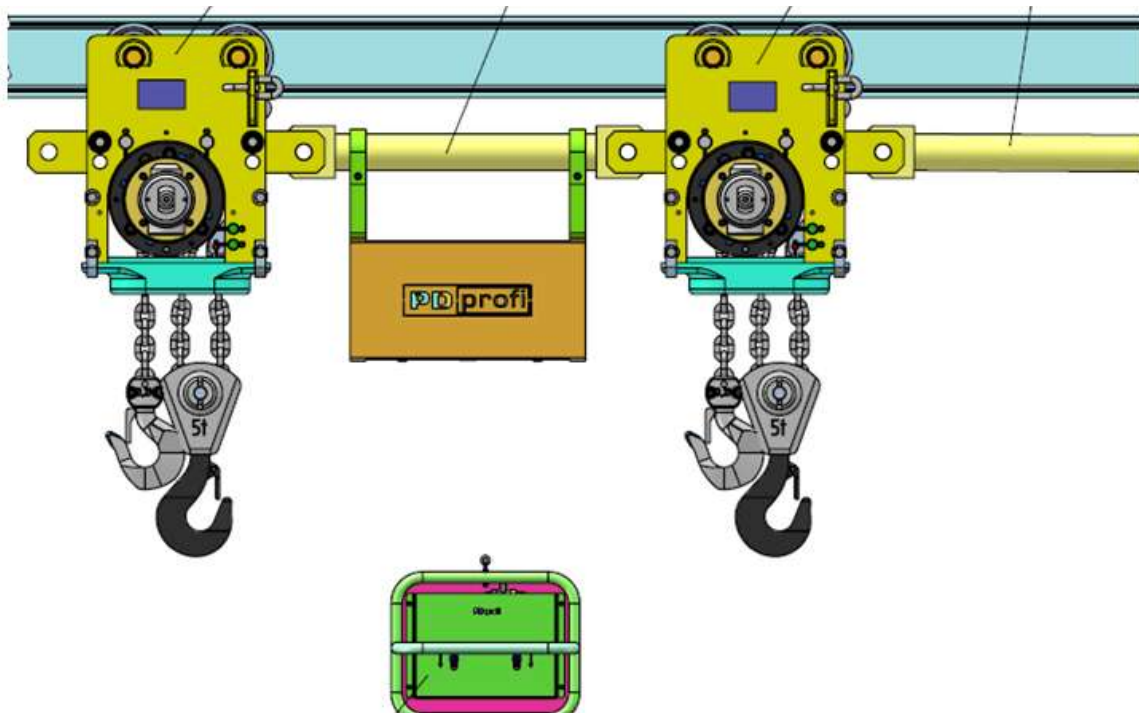

TECHNICAL PARAMETERS:

Maximum tension load MZP 2x3,2t/5t (6t)	[kN]	100(120)
Axis distance of hooks (hitches)	[mm]	as required
Elevation of hooks (basic)	[mm]	3000
Max. loading	[t]	2 x 3,2/5, 2 x 3,2/6
Max. incline during lifting	[°]	±20
Operating pressure	[MPa]	0,4-0,6
Weight	[kg]	Approx. 340kg

THE MZP 2x3.2t MANUAL MOBILE MANIPULATION DEVICE

DESCRIPTION:

The MZP 2x3.2t mobile manipulation device is used for transport of material in mining operations along the ZD 24 type hanging tracks.

The MZP 2x3.2t mobile manipulation device consists of two ZMPP 3.2t manipulation devices connected by a connecting rod. MZP 2x3.2t can be pulled, for example, by the MK10 manipulation trolley connected by the connecting rod. Both ZMPR 3.2t manipulation devices are operated by manual control chain. A brake cart is not a part of delivery.

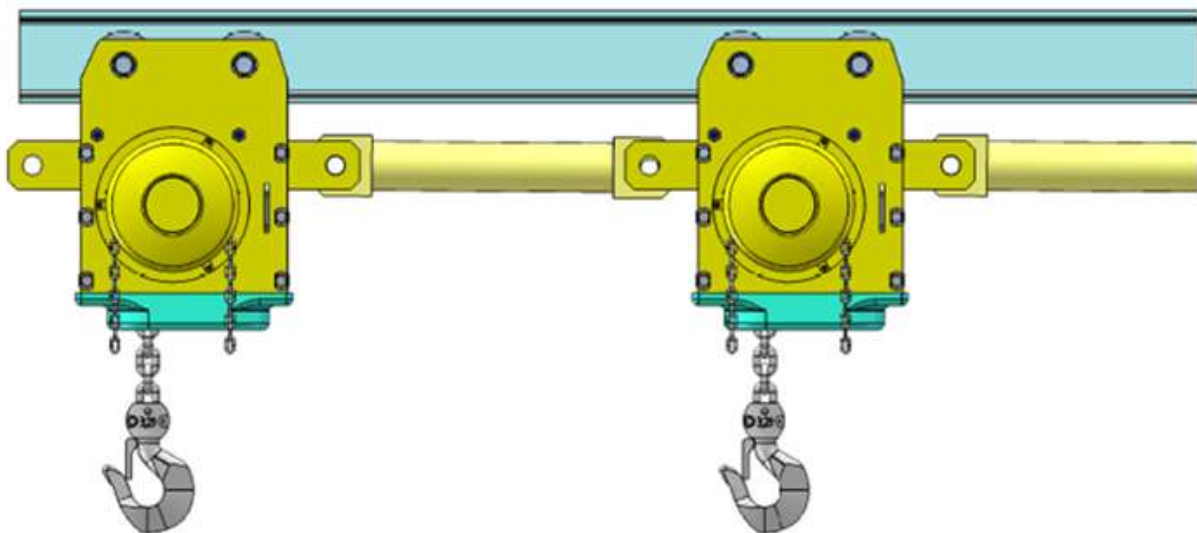

TECHNICAL PARAMETERS:

Maximum tension load MZP 2x3.2/5t	[kN]	6,4
Axis distance of hooks (hitches)	[mm]	as required
Lift of hooks (basic)	[mm]	3000
Max. loading	[t]	2 x 3,2
Max. incline during lifting	[°]	±20
Total weight	[kg]	Approx. 300kg

PNEUMATIC TRANSPORT EQUIPMENT ZTP 2x3,2t

DESCRIPTION:

Pneumatic transport equipment **ZTP 2x3,2t** is used for transport of material in mines on hanging grooves, type ZD 24.

Pneumatic transport equipment **ZTP 2x3,2t** consists of frame with lifting equipment, operating and connecting pull rod. Two trolleys are used to hang it on the rails. The lifting part is composed by two units, formed by a hoist with pneumatic brake motor. The movement of the lifting chain is drawn by the nut of the hoist. The chain continues further inside the frame to an adjustable shuttle and towing hook with turn that protects the chain from twisting. Shuttles, together with the pitch between towing hooks, can be easily adjusted in the range from 1.4 m up to 3.8 m in steps by 0.1 m. The unloaded end of the chain is laid aside into the storage grip. The pneumatic control is hanged on the connecting pull rod, outside the dangerous area of hanging weight.

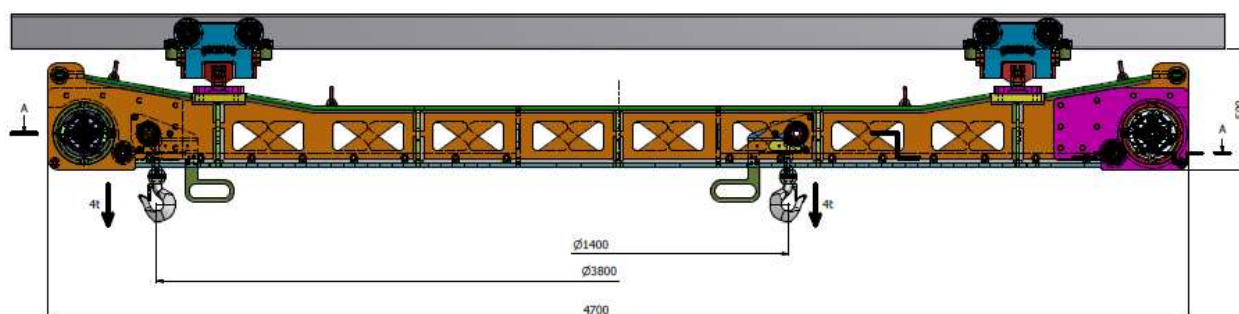

TECHNICAL PARAMETERS:

Maximum tension load ZTP 2x3,2t	[kN]	62
Axis distance of hooks	[mm]	1400 - 3800
Elevation of hooks (basic)	[mm]	3000
Max. loading	[t]	2 x 3,2
Max. incline during lifting	[°]	±20
Operating pressure	[MPa]	0,4-0,6
Weight	[kg]	Approx. 850

PNEUMATIC MANIPULATION SET SMP 1

DESCRIPTION:

The **SMP 1** pneumatic manipulation set is used for transport of material in mining operations along the ZD 24 type hanging tracks.

The **SMP 1** pneumatic manipulation set consists of two pneumatic travelling manipulation units ZMPP 3.2t/5t or ZMPP 3.2t/6t that are controlled by the OP 2 pneumatic control. The units are connected by connecting rods and pulled by the MK10-16 000N manipulation trolley. A brake cart is not a part of delivery.

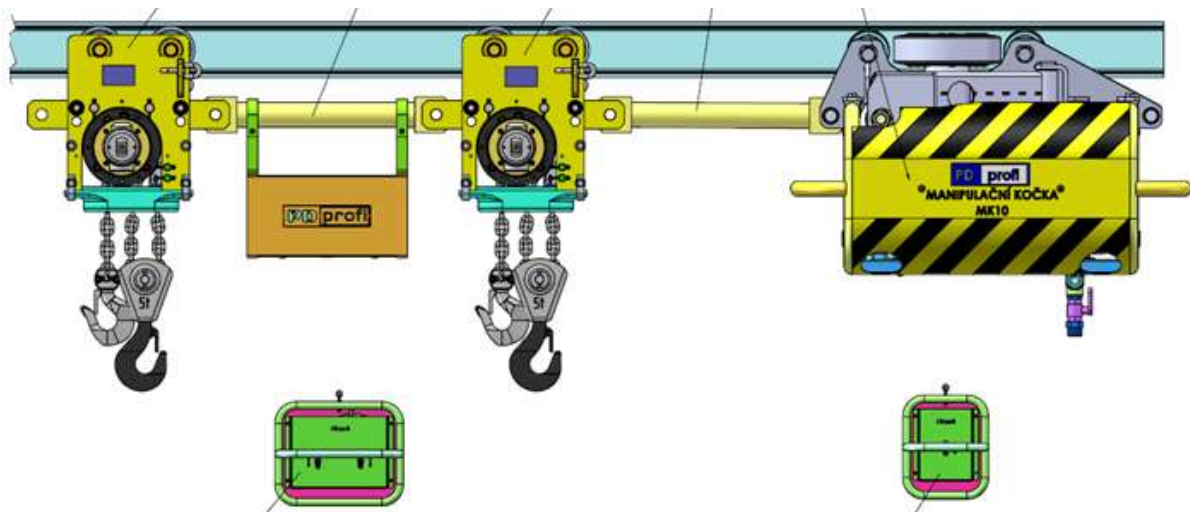

TECHNICAL PARAMETERS:

Nominal traction force	[N]	16 000
Axis distance of hooks (hitches)	[mm]	as required
Elevation of hooks (basic)	[mm]	3000
Max. loading	[t]	2 x 3,2/5, 2 x 3,2/6
Inside diameter of the supply hose	[mm]	32
Max. incline during lifting	[°]	±25
Working medium pressure	[MPa]	0,4-0,6
Total weight	[kg]	Approx. 710 kg

PNEUMATIC MANIPULATION SET SMP 2

DESCRIPTION:

The **SMP 2** pneumatic manipulation set is used for transport of material in mining operations with lowered travel profile along the ZD 24 type hanging tracks.

The **SMP 2** pneumatic manipulation set consists of two pneumatic travelling manipulation units ZMPP 3.2t/5t or ZMPP 3.2t/6t that are controlled by the OP 2 pneumatic control. The units are connected by connecting rods and pulled by the MK10.1-16 000N manipulation trolley with a VB 25 cart with a brake and the frame with the trolley pneumatic control. The VB 25 cart can be equipped by a speed limiter. A brake cart is not a part of delivery.

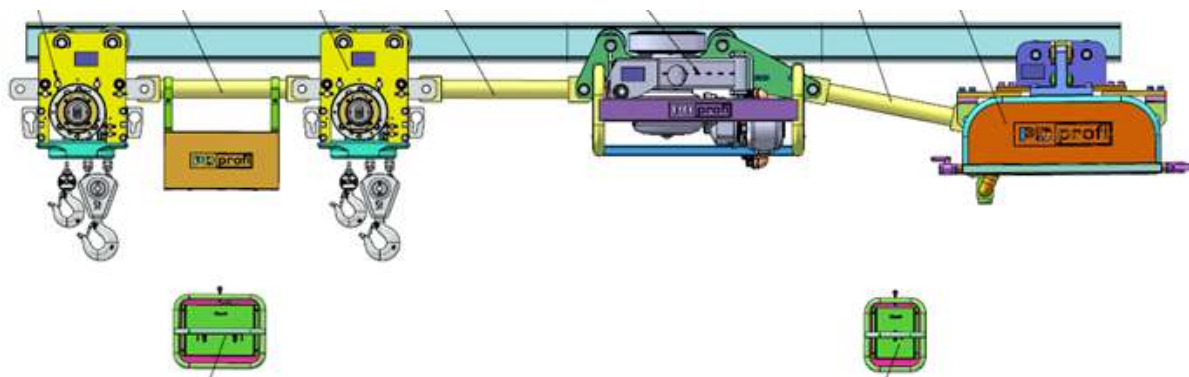

TECHNICAL PARAMETERS:

Nominal traction force	[N]	16 000
Axis distance of hooks (hitches)	[mm]	as required
Elevation of hooks (basic)	[mm]	3000
Max. loading	[t]	2 x 3,2/5, 2 x 3,2/6
Inside diameter of the supply hose	[mm]	32
Max. incline during lifting	[°]	±25
Working medium pressure	[MPa]	0,4-0,6
Total weight	[kg]	Approx. 800 kg

THE PL 0.25t AND 0.5t PNEUMATIC TACKLES

DESCRIPTION:

The PL 0.25t a 0.5t pneumatic tackles consist of the body with a hook set, multi-plate motor and a pneumatic control.

The PL 0.25t a 0.5t pneumatic tackles are used as classical stable hoists to lift and lower loads at places with the supply of compressed air:

- as a manipulation hoist for installation and maintenance work in all kinds of technological operations
- it is especially useful in the dust or gas explosion danger environments, where electric motor hoists cannot be used (gasworks, deep mines, chemical plants etc.)
- version with the NEXP designation



TECHNICAL PARAMETERS:

Loading	[t]	0,25	0,5
Load chain	[mm]	4x12	2x (4x12)
Operating pressure	[MPa]	0,4 – 0,6	
Nominal motor output	[kW]	0,8	
Lifting speed	[m.mim ⁻¹]	0,5	0,5
Air consumption	[m ³ h ⁻¹]		
Filtration	[µm]	50	
Weight	[kg]	15	16
Inside diameter of the supply hose	[mm]	Ø13	

THE RZC RATCHET HOISTS – NEXP

DESCRIPTION:

The RZC ratchet hoists consist of the body with hook and gear assembly, control lever and load-link chain with a hook.

The RZC ratchet hoists are widely used in places where loads need to be manipulated in the explosion danger environment. By their design these hoists meet requirements set for the group I (mining), category M2 devices.

- for lifting and dragging of loads
- for tensioning of fences, salvage work, pulling out of supports
- as lifting devices for mine hanging tracks
- for assembly and manipulation work of all kinds
- suitable for use in heavy duty operations - mines, chemical industry etc.

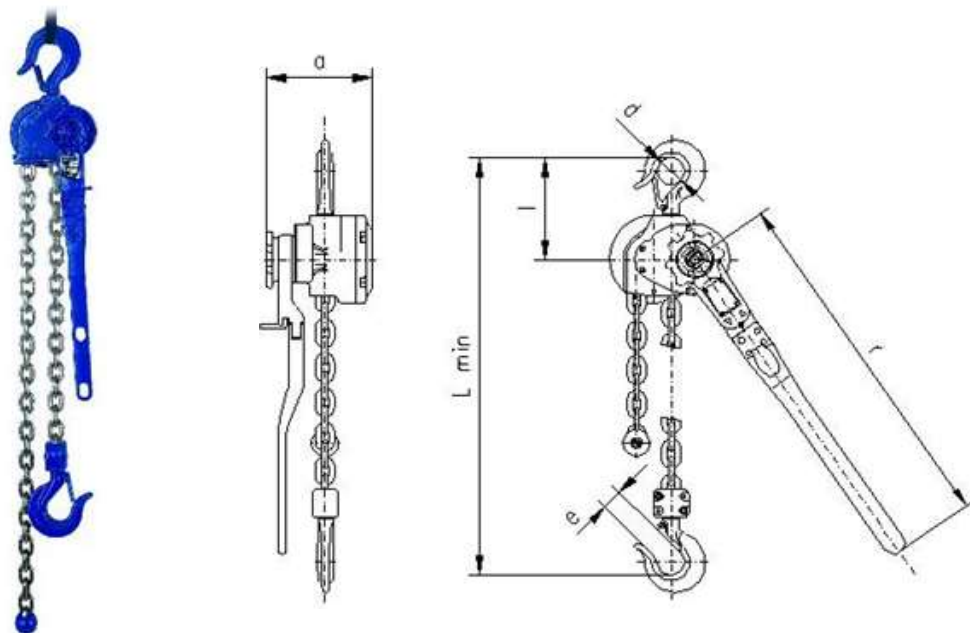

TECHNICAL PARAMETERS:

Loading (t)	Number of load strands	Load chain	Control force (N)	Lifting speed (m/min)	Basic dimensions (mm)						Weight (kg)	Weight gain per 1m of lift (kg)
					a	d	e min	l	L min	r		
0,8	1	Ø 5 x 15	400	1,27	145	36	23,5	145	327	560	8,9	0,55
1,6	1	Ø 9 x 27	370	0,52	165	43	29,5	160	380	560	16,7	1,84
3,2	1	Ø 11 x 31	400	0,37	173	50	35,5	223	417	560	21	2,73
5	2	Ø 11 x 31	300	0,18	173	56	42	242	630	560	34	5,46
6,3	2	Ø 11 x 31	400	0,18	173	63	48	265	650	560	40	5,46

THE RZV RATCHET HOISTS – NEXP

DESCRIPTION:

The RZV ratchet hoists consist of the body with hook and gear assembly, control lever and load-roller chain with a hook.

The RZV ratchet hoists are widely used in places where loads need to be manipulated in the explosion danger environment. By their design these hoists meet requirements set for the group I (mining), category M2 devices.

- for lifting and dragging of loads
- for tensioning of fences, salvage work, pulling out of supports
- as lifting devices for mine hanging tracks
- for assembly and manipulation work of all kinds
- suitable for use in heavy duty operations - mines, chemical industry etc.

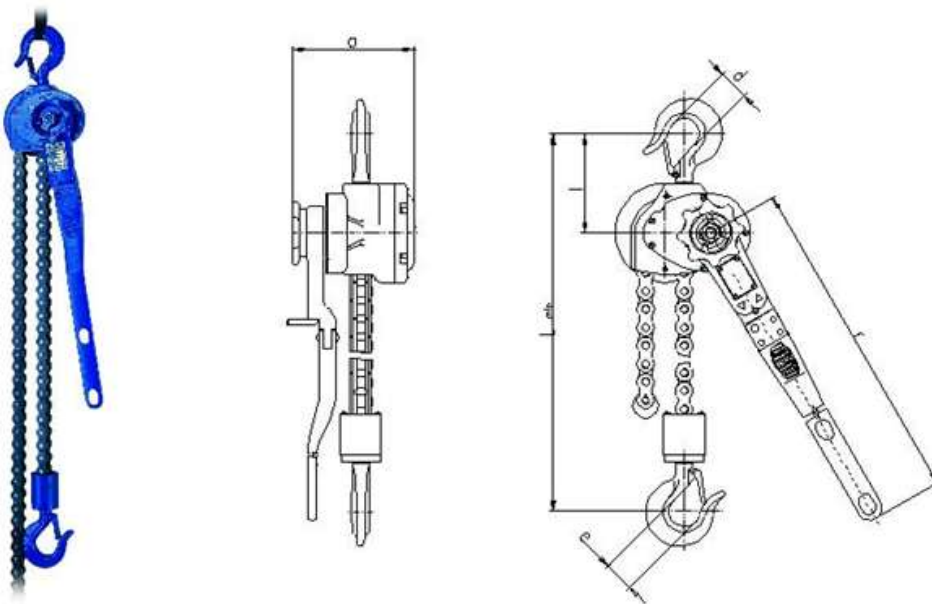

TECHNICAL PARAMETERS:

Loading (t)	Number of load strands	Control force (N)	Lifting speed (m/min)	Basic dimensions (mm)						Weight (kg)
				a	d	e (mm)	l	L (mm)	r	
0,8	1	400	1,27	145	36	23,5	145	327	560	9,4
1,6	1	370	0,52	165	43	29,5	160	395	560	16,5
3,2	2	370	0,26	165	50	35,5	223	500	560	24
5	3	440	0,22	160	56	39,5	213	555	560	41
6,3	4	430	0,17	160	63	48	260	640	560	46

THE ROPE HOISTS

DESCRIPTION:

The rope hoists consist of the body with hook and gear assembly, control lever and a rope with a hook.

They are widely used especially in construction, agriculture, forestry, transport etc., for example:

- for lifting and dragging of loads in all directions
- for salvage work and construction demolitions
- for erecting of posts, installation of electrical lines, tensioning of cableway return trolleys
- for logging
- for installation and manipulation work of all kinds

Ropes are delivered separately, wound on rope reels. The rope length is optional from the 10, 20, 30 and 40m lengths. Longer ropes need to be special ordered.

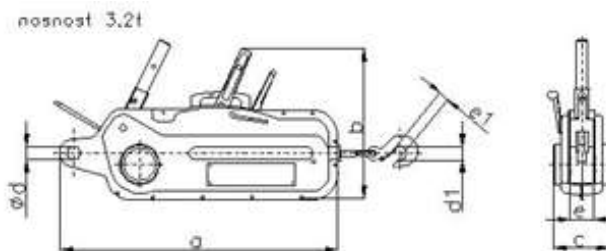
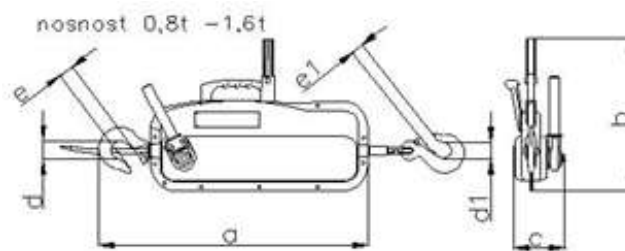

TECHNICAL PARAMETERS:

	Loading (t)	Lifting speed (m/min)	Control force (N)	Basic dimensions (mm)							Weight (kg)
				a	b	c	d	d1	e	e1	
30-10	0,8	2	250	535	260	125	36	32	23,5	23,5	11,5
30-00	1,6	2	450	630	365	155	43	46	32,5	32,5	21,5
30-11	3,2	0,45 0,84	380 (B) 750 (A)	680	345	140	28	64	47	45,5	33,5

THE Z100 CHAIN TROLLEYS

DESCRIPTION:

THE Z100 chain trolleys consist of the body with hook, gear box and manual wheel and the load chain with hook.

THE Z100 chain trolleys are used as classical stable manually operated hoists for lifting and lowering of loads

- especially suitable for use in places where hoists are not used extensively
- for occasional work
- in places without a power source
- as the service hoist for assembly and maintenance work in all kinds of technological operations
- they can be used in the explosion danger environment (the NEXP designation)

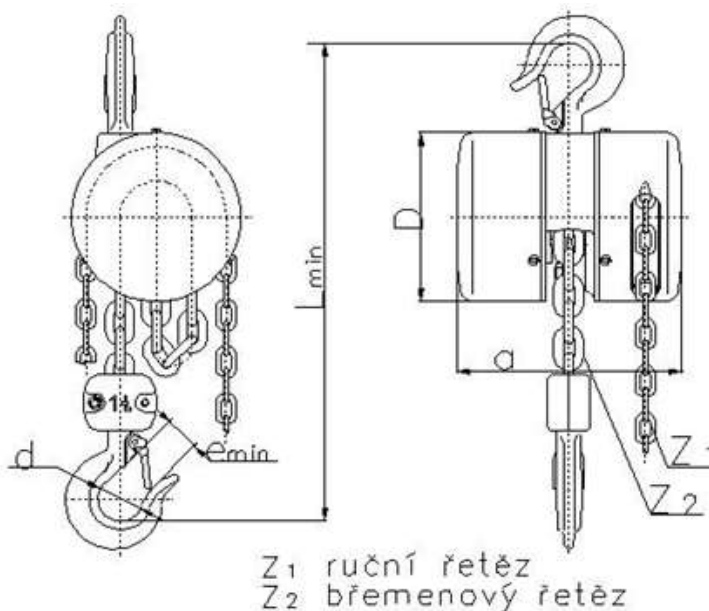

TECHNICAL PARAMETERS:

	Loading (t)	Number of load strands	Load chain	Hand chain	Control force (N)	Lifting speed (m/min)	Basic dimensions (mm)					Weight (kg)
							a	d	D	e (min)	L (min)	
Z 100	0,5	1	Ø 5 x 15	Ø 4 x 20	300	1,10	165	30	115	18,5	250	10
Z 100-1	1	1	Ø 7 x 21	Ø 4 x 20	350	0,70	180	36	136	23,5	330	12,5
Z 100	1,6	1	Ø 9 x 27	Ø 4 x 20	320	0,36	220	43	198	29,5	410	25
Z 100-1	3,2	1	Ø 11 x 31	Ø 4 x 20	400	0,29	254	50	220	35,5	510	36,5
Z 100-2	5	2	Ø 11 x 31	Ø 4 x 20	400	0,145	254	56	220	39,5	655	57
Z 100	7,5	2	Ø 11 x 31	Ø 4 x 20	480	0,15	254	56	220	43	875	70
	10	3	Ø 11 x 31	Ø 4 x 20	400	0,10	254	63	200	47	1000	85

SHOE RACK JACKS

DESCRIPTION:

Shoe rack jacks consist of the casing, rack with a shoe and operating handle with gears.

The shoe rack jacks are widely used especially in construction and mining industries and everywhere, where loads need to be manipulated.

- for lifting and manipulation with all kinds of loads
- for installation work especially in construction
- they can be used in the explosion danger environment (the NEXP designation)

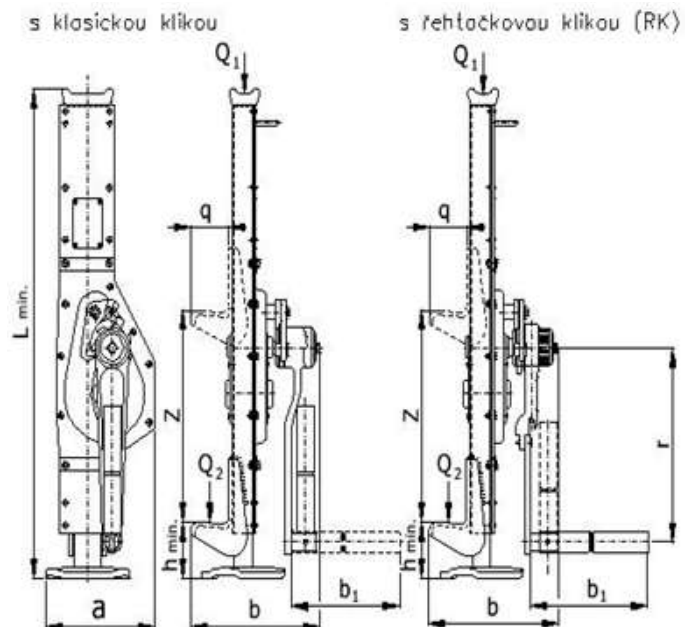

TECHNICAL PARAMETERS:

	Loading (t)		Control force (N)	Basic dimensions (mm)								Weight (kg)
	Q1	Q2		a	b	b1	q	h min	L min	r	Z	
15-00	2,5	1,8	380	162	198	200	61	73	735	250	345	15
15-00 RK												16
15-00	5	3,5	550	188	235	200	77	83	765	300	360	22
15-00 RK												23
15-01	10	7	540	234	290	200	95	90	770	300	320	38
15-01 RK												39
15-01	16	11	730	280	315	280	92	160	900	400	320	65
Z23	20	14	800	325	330	280	85	150	960	400	300	90

THE VR 1 HAND CART

DESCRIPTION:

The VR 1 hand cart is used for manual transport of loads of up to 60kg along the ZD 24 hanging track. The cart can be put on at any place on the track. The cart is operated using a strap through a pawl that will block the cart at the nearest track joint if it runs away.

- The VR 1 hand cart consists of:
- Two arms with driving wheels
 - Two pawls with return springs
 - Hanging
 - Control strap

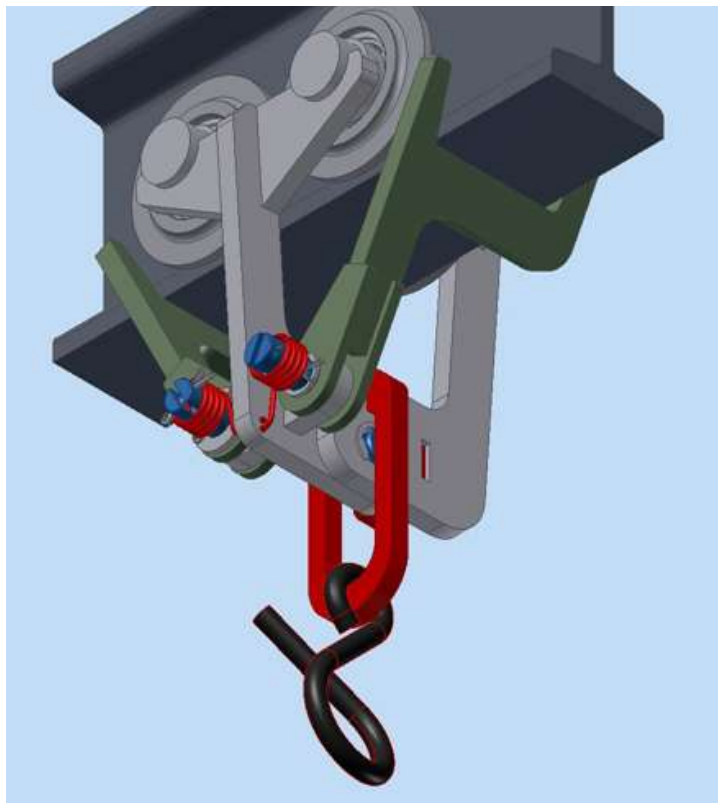

TECHNICAL PARAMETERS:

Loading	[kg]	60
Max. travel speed on level surface	[mm]	20
Maximum path incline	[°]	30
Basic dimensions	[mm]	150 x 390 x 215
Weight	[kg]	5,5

THE JKL AND KO UNIVERSAL TACKLES

DESCRIPTION:

The JKL and KO universal tackles are used for manipulation in mines, in construction for lifting of loads and materials using a steel rope. The tackles are designed with fourfold safety limit over the failure strength. These tackles can be used everywhere with fourfold strength of construction over failure limit and the ratio of the tackle diameter to rope one at least $D/d=7$. Size of the hanging eyelet allows double hanging of the tackle by, for example, high-strength chain.

JKL 231 – The auxiliary front tackle for leading of a steel rope during transport and manipulation of loads, where the tackle load does not exceed 12kN (2x6kN at the wrap angle 180°)

JKL 42/1 – The tackle for leading of a steel rope during transport and manipulation of loads, where the tackle load does not exceed 92kN (2x46kN at the wrap angle 180°). The rope is inserted by lifting off of the safety catch.

KO 2x60kN - The tackle consists of the oval eyelet with shank hinge attached in the tackle body and turning side that is secured by a pin extendable into the body of the tackle. It is used for the maximum tension in the rope of 60kN and the angle of wrap 180°.



TECHNICAL PARAMETERS:

		JKL 231	JKL 42/1	KO 2 x 60kN
Max. pulley load	kN	2 x 6	2 x 46	2 x 60
Max. Ø of rope	mm	16	20	20
Pulley diameter	mm	120	128	142
Basic dimensions	mm	160 x 240 x 108	168 x 450 x 124	220 x 158 x 452
Weight	kg	4,3	12	25

VRÁTEK VLEČNÝ PNEUMATICKÝ VVP 10

DESCRIPTION:

The VVP pneumatic towing winch is used for transport and moving of material, machines and their parts in mines along horizontal tracks.

The VVP pneumatic towing winch consists of the following basic parts:

- Winch frame with drum
- Pneumatic gear motor MPZ 3.5
- Control with pneumatic distribution

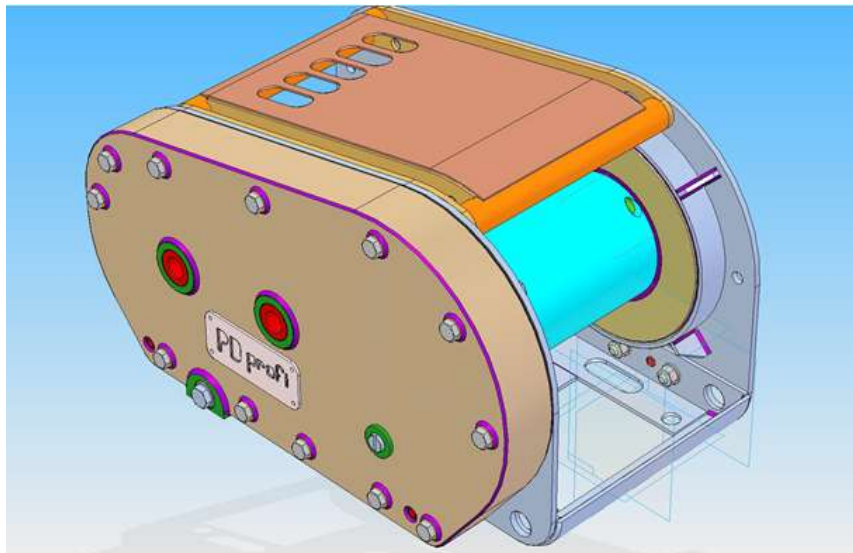

TECHNICAL PARAMETERS:

Max. tension within rope	[kN]	9,6
Rope length of the 8mm diameter rope	[m]	65
Operating pressure	[MPa]	0,4
Nominal motor output	[kW]	3,2
Medium rope speed	[m.s ⁻¹]	0,36
Air consumption	[m ³ h ⁻¹]	350
Filtration	[µm]	50
Weight	[kg]	75
Inside diameter of the supply hose	[mm]	25

THE VP 40 PD REMOVAL WINCH

DESCRIPTION:

The VP 40 PD removal winch is a device intended for purposes requiring large traction strength and slow rope speed, for example for removal of supports, steel equipment etc.

The winch consists of these main parts:

- Frame
- Pneumatic gear motor MPZ 15
- Gears with shifting device
- Drum with planetary gears and cover
- Limit rollers

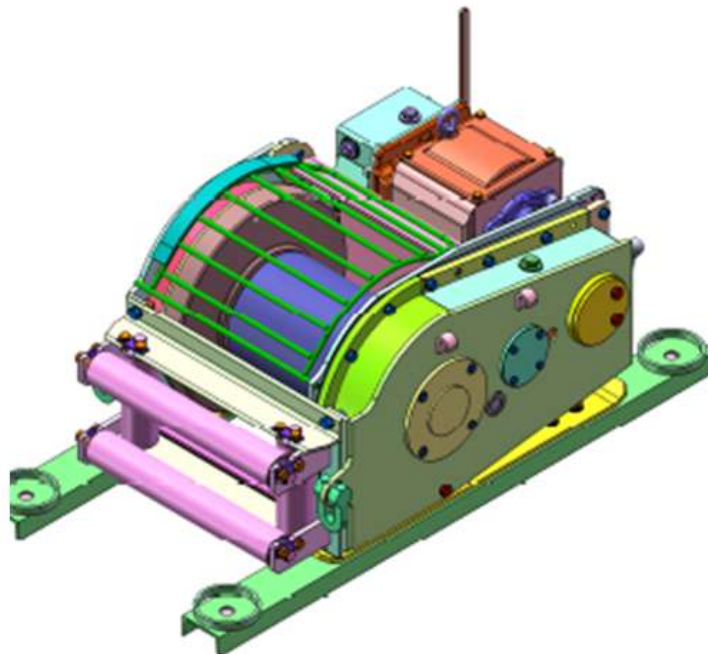

TECHNICAL PARAMETERS:

Max. tension within rope	[kN]	58,2
Rope length of the 20mm diameter rope	[m]	125
Operating pressure	[MPa]	0,4
Nominal motor output MPZ 15	[kW]	15
Medium rope speed	[m.s ⁻¹]	1,52
Air consumption	[m ³ h ⁻¹]	950
Filtration	[µm]	50
Weight	[kg]	1000
Inside diameter of the supply hose	[mm]	ø 50

THE VP 40 PD TOWING WINCH

DESCRIPTION:

The VP 40 PD towing winch is a device intended for purposes requiring large traction strength and slow rope speed, for example for transport of material by skidding along a coalface etc.

The winch consists of these main parts:

- Frame
- Pneumatic gear motor MPZ 15
- Gears with shifting device
- Drum with planetary gears and cover
- Limit rollers
- Band foot brakes

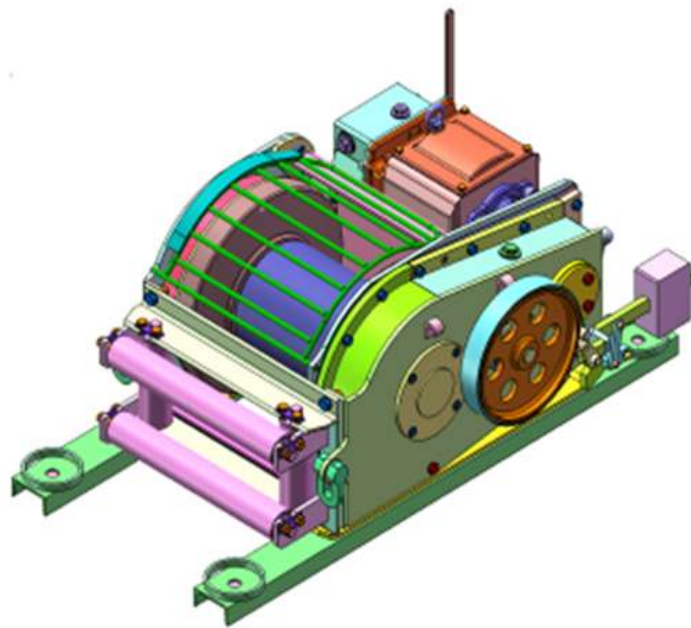

TECHNICAL PARAMETERS:

Max. tension within rope	[kN]	58,2
Rope length of the 20mm diameter rope	[m]	125
Operating pressure	[MPa]	0,4
Nominal motor output MPZ 15	[kW]	15
Medium rope speed	[m.s ⁻¹]	1,52
Air consumption	[m ³ h ⁻¹]	950
Filtration	[µm]	50
Weight	[kg]	1100
Inside diameter of the supply hose	[mm]	Ø 50

THE VTA 1000 MINING WINCH

DESCRIPTION:

The VTA 1000 mining winch is a device that is used for transport and moving of material, machinery and its parts in mines along horizontal and inclined transport routes.

The winch consists of these main parts:

- Winch frame
- Pneumatic gear motor (electric motor)
- Band brakes including brake control levers
- Drum with planetary gears and cover
- Limit rollers
- Drum cover

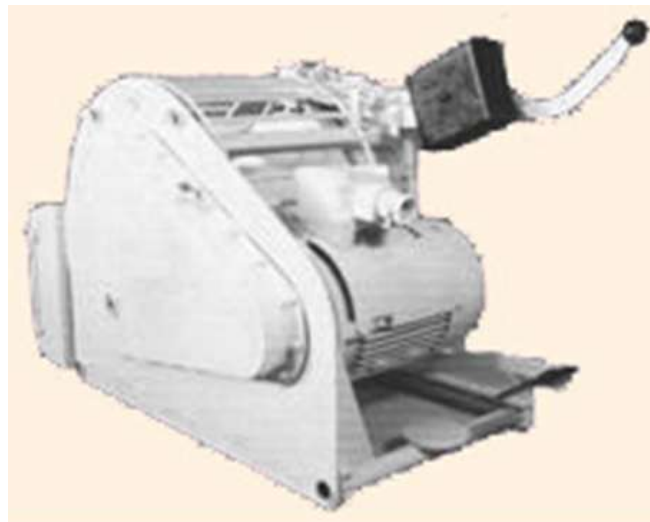

TECHNICAL PARAMETERS:

		pneumatic gear motor	Electric motor
Max. tension within rope	[kN]	12,8	10,8
Rope length of the 14mm diameter rope	[m]	310	
Operating pressure	[MPa]	0,4	-
Nominal motor output MPZ 15	[kW]	13	11
Medium rope speed	[m.s ⁻¹]	1	
Air consumption	[m ³ h ⁻¹]	900	-
Filtration	[µm]	50	-
Weight	[kg]	769	
Inside diameter of the supply hose	[mm]	Ø 50	-

THE MPZ 3.5 PNEUMATIC GEAR MOTOR

DESCRIPTION:

The MPZ 3.5 pneumatic gear motor is used to power machinery, manipulation devices etc., especially in the explosion danger environment (mines, chemical industry etc.)

The MPZ 3.5 pneumatic gear motor consists of two gear rotors placed in a steel body sealed using two steel flanges. The motor can be attached to equipment using a flange or a shoe. The change of motor revolutions is done by a pneumatic valve that is placed outside of the motor.

It is manufactured in the following versions: P1- flanged
P2- flanged and braked

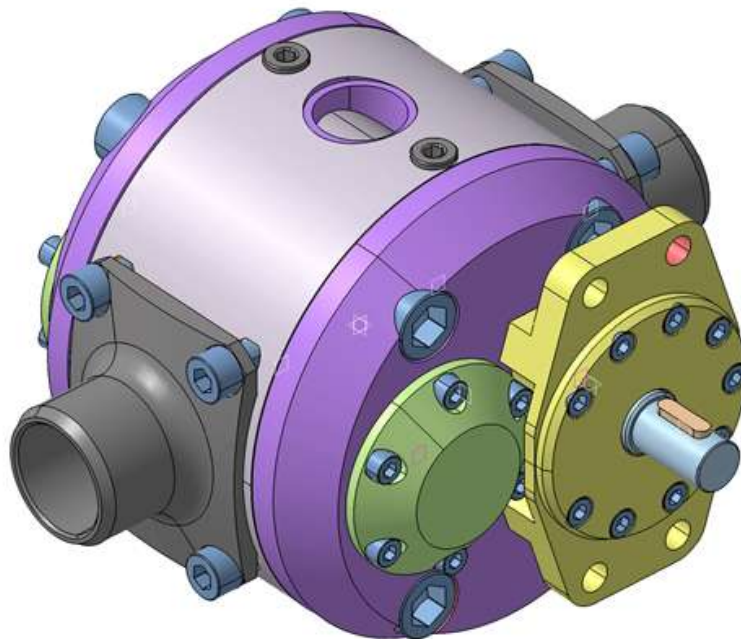

TECHNICAL PARAMETERS:

Operating pressure	[MPa]	0,35-0,4
Nominal motor output MPZ 15	[kW]	3,5
RPMs	[min ⁻¹]	3000
Air consumption	[m ³ h ⁻¹]	350
Filtration	[µm]	50
Basic dimensions	[mm]	Ø 180 x 200
Weight	[kg]	20
Inside diameter of the supply hose	[mm]	Ø 25mm

THE MPZ 15 PNEUMATIC GEAR MOTOR

DESCRIPTION:

The MPZ 15 pneumatic gear motor is used to power machinery, especially winches and drag-link conveyors, especially in the explosion danger environment (mines, chemical industry etc.)

The MPZ 15 pneumatic gear motor consists of two gear rotors placed in a cast-iron stator with flanges, distribution box with integrated lubrication, revolution regulator and air muffler. The motor can be attached to machines using a flange. The change of revolutions is performed manually using a lever on the distribution box.

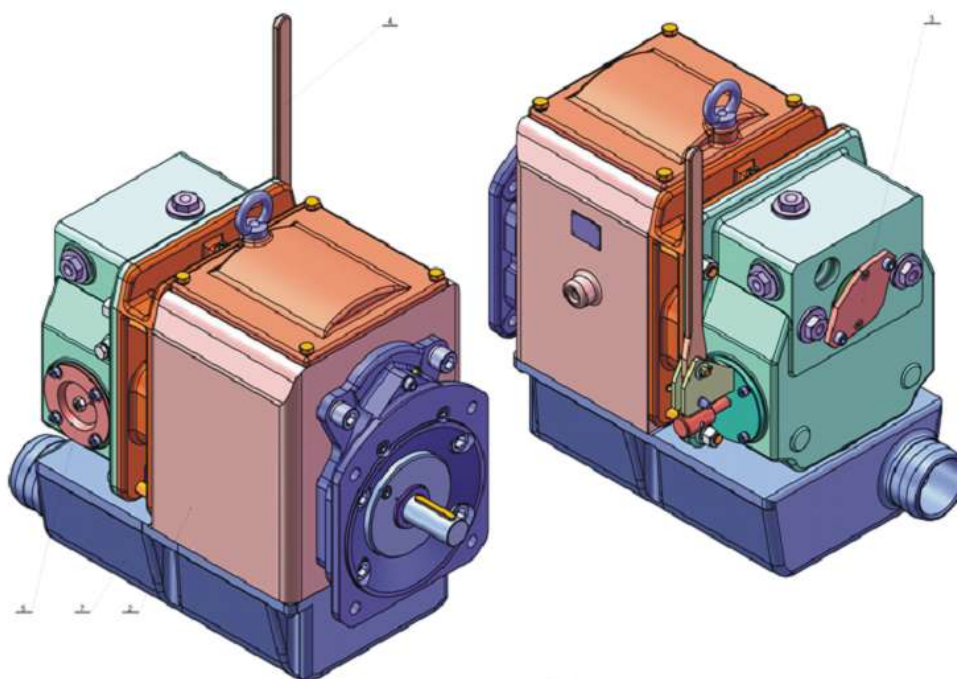

TECHNICAL PARAMETERS:

Operating pressure	[MPa]	0,4
Nominal motor output MPZ 15	[kW]	15
RPMs	[min ⁻¹]	1450
Air consumption	[m ³ h ⁻¹]	950
Filtration	[µm]	50
Basic dimensions	[mm]	407 x 534 x 548
Weight	[kg]	228
Inside diameter of the supply hose	[mm]	Ø 50mm

THE MPP 2 PNEUMATIC PISTON MOTOR

DESCRIPTION:

The MPP 2 pneumatic piston motor is used to power machinery, manipulation devices etc, especially in the explosion danger environment (mines, chemical industry etc.)

The MPP 2 pneumatic piston motor is designed as radial four cylinder engine with slide valve distribution and automatic multi-plate brake.

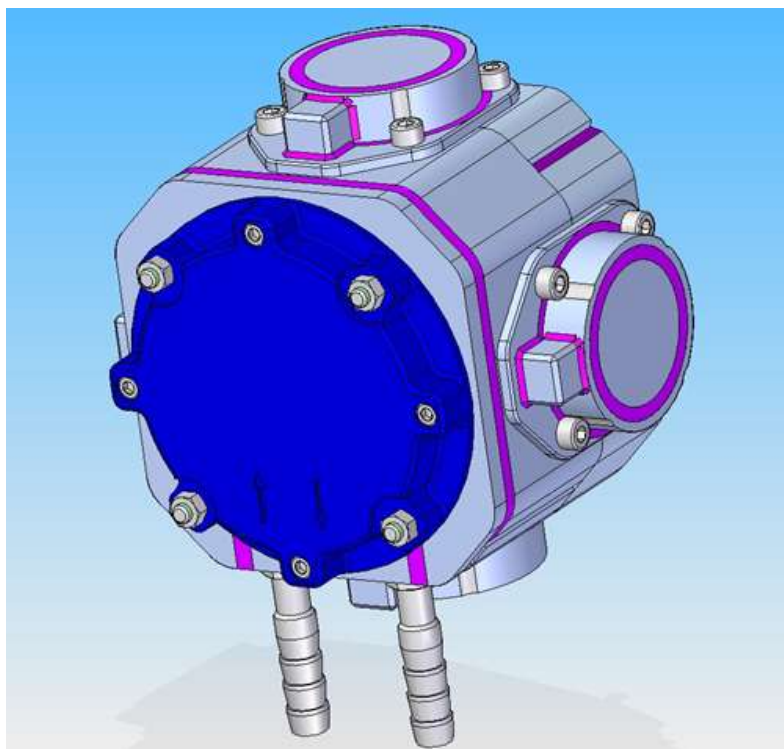

TECHNICAL PARAMETERS:

Operating pressure	[MPa]	0,45-0,6
Nominal motor output MPZ 15	[kW]	2
RPMs	[min ⁻¹]	600
Air consumption	[m ³ h ⁻¹]	37
Filtration	[µm]	50
Basic dimensions	[mm]	Ø 250 x 200
Weight	[kg]	20
Inside diameter of the supply hose	[mm]	Ø 15mm

THE MPP 3 PNEUMATIC PISTON MOTOR

DESCRIPTION:

The MPP 3 pneumatic piston motor is used to power machinery, manipulation devices etc, especially in the explosion danger environment (mines, chemical industry etc.)

The MPP 3 pneumatic piston motor is designed as radial cylinder engine with slide valve distribution and automatic multi-plate brake.

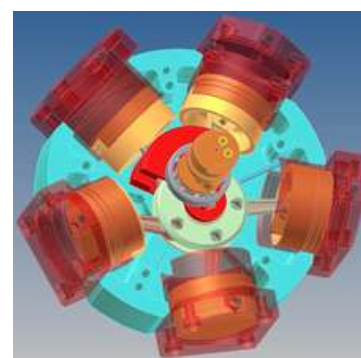
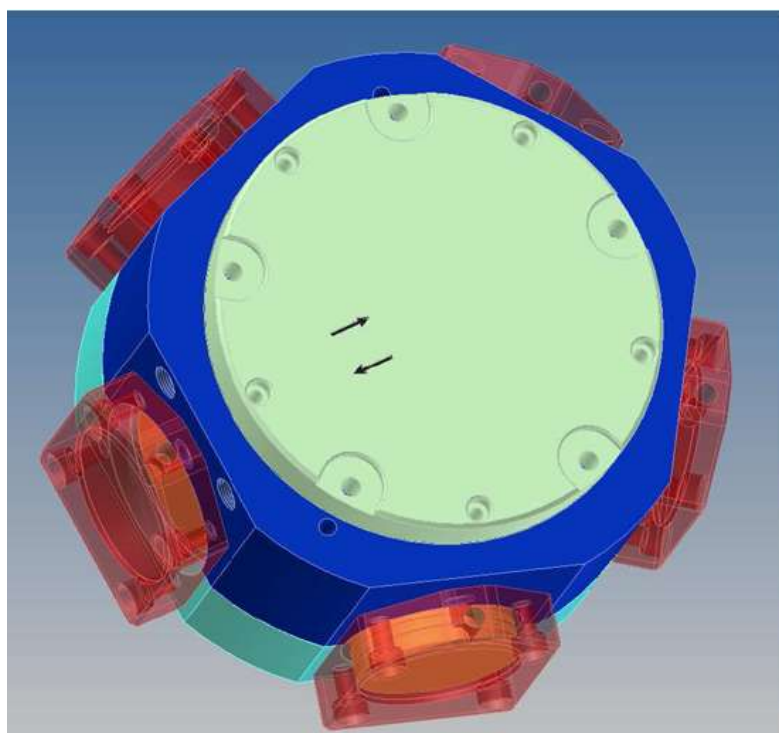

TECHNICAL PARAMETERS:

Operating pressure	[MPa]	0,45-0,6
Nominal motor output MPZ 15	[kW]	3
RPMs	[min ⁻¹]	600
Air consumption	[m ³ h ⁻¹]	100
Filtration	[µm]	50
Basic dimensions	[mm]	Ø 220 x 200
Weight	[kg]	35
Inside diameter of the supply hose	[mm]	Ø 20 mm

THE MPL 3 PNEUMATIC MULTI-PLATE MOTOR

DESCRIPTION:

The MPL 3 pneumatic multi-plate motor is used to power machinery, manipulation devices etc., especially in the explosion danger environment (mines, chemical industry, etc.)

The MPL 3 pneumatic multi-plate motor consists of a bidirectional multi-plate motor, two stage planetary transmission, and an automatic multi-plate brake.

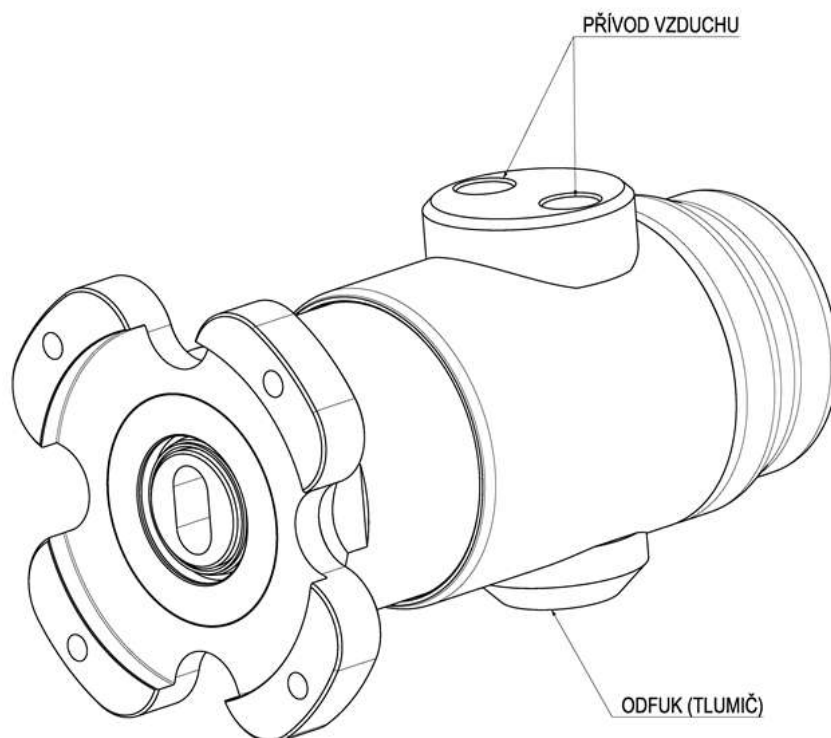

TECHNICAL PARAMETERS:

Operating pressure	[MPa]	0,4-0,6
Nominal output	[kW]	3±10%
Nominal revs	[min ⁻¹]	600
Air consumption	[m ³ h ⁻¹]	144
Filtration	[µm]	50
Basic dimensions (w x l)	[mm]	Ø 108 x 272
Weight	[kg]	13,4
Air supply	[mm]	Ø 20 mm



ISO 9001:2009



THE NPP 1 PNEUMATIC BELT WINDER

DESCRIPTION:

The NPP 1 pneumatic belt winder is a piece of machinery placed behind a belt conveyor. To drive the winding cylinders located in the frame NPP 1 uses a part of VP 40PD removal winch transmission and the pneumatic gear motor MPZ 15. This air motor allows to wind the belt to the winding cylinders by its driving force, and thus take and wind the belt that is left over after shortening of a belt conveyor. During shortening of a belt conveyor the belt is disconnected at the bottom branch above NPP 1. One end of the disconnected belt lining (from drive end) is secured on the main winding cylinder of NPP 1 using two M 16 bolts. The other end secured using shortening stops in front of stationary tensioning device (further called STANAP) that is a part of the conveyor belt. The operator starts NPP 1 and winds the extra belt lining on it. After winding of the extra length of belt onto the main winding cylinder the belt lining is cut and the remaining length is again connected by sewing to the existing one secured at STANAP. At NPP 1 the wound belt lining is rewound from the main winding cylinder to the back-up winding cylinder using the air motor with the gear from the VP 40PD removal winch. Winding to the main cylinder is done the same way during the second shortening of conveyor belt, but the belt from the back-up winding cylinder is connected by sewing to the existing belt in front of STANAP, however, it is not secured there. Both the necessary shortened length and the extra PVC from the back-up winding cylinder are wound to the main winding cylinder. After the shortened belt on the belt conveyor is connected, the extra belt is taken away. NPP 1, whose frame with the cylinders is placed on rails, can, by using MZPP 1.6t/3.2t handling device located on the NPP 1 construction, move this frame from under the belt conveyor to the passage under the hanging rail transport track. After the NPP 1 frame is moved under the transport track, the main winding cylinder that is secured (four M 16 bolts) in the frame is released and loaded on the hanging rail vehicles. A new main winding cylinder is then inserted to the empty frame of NPP 1, then it is secured, and the whole frame that is thus prepared is moved using MZPP 1.6t/3.2t under the conveyor belt construction behind the conveyor drive, and is ready for further use.

The basic NPP 1 parameters are the pulling force of 46.6 kN for belt winding, and 16 kN pulling force to transfer the NPP 1 frame. NPP 1 serves only for winding of belt lining and its transfer under the transport track. The maximum length of wound belt lining cannot exceed 100 m length, 1 400 mm width, and 4 000 kg weight.

NPP 1 is a device that can be operated in the underground parts of mines that are classified with methane explosion danger according to Section 232, Par. 1, Letter b) and coal dust according to Section 233, Par. 1, Letter b) of the CBU Notice No. 22/1989 Coll., as amended, including mines with the danger of rock falls and gas outbursts, and mines with dangerous mining tremors.

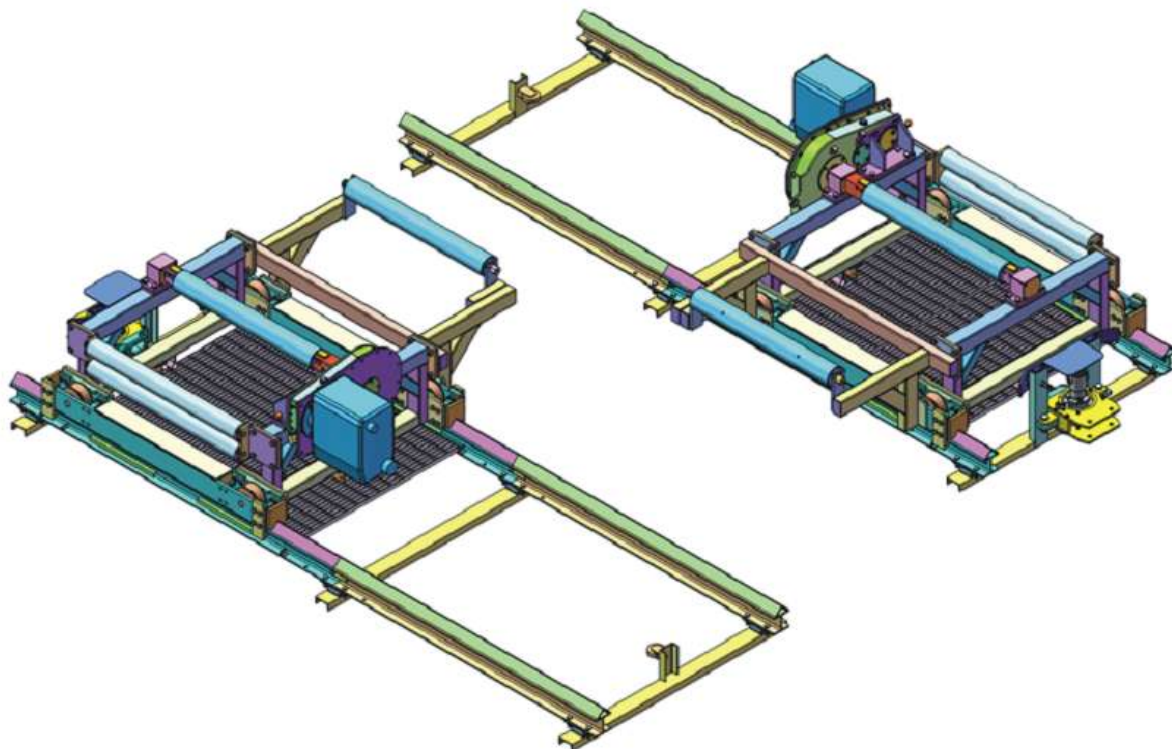

TECHNICAL PARAMETERS:

Belt winding pulling force	[N]	46 600
Frame transfer pulling force	[N]	16 000
Max. travel speed on level surface	[m.min. ⁻¹]	24
Belt winding installed power	[kW]	15
Frame transfer installed power	[kW]	3
Operational air pressure	[MPa]	0,4
Inside diameter of the supply hose	[mm]	50
Max. belt length	[m]	100
Max. width of belt	[mm]	1 400
Max. weight of belt	[kg]	4 000
Dimensions – h x w x l	[mm]	5681 x 2659 x 1308



ISO 9001:2009



HYDRAULIC BELT AND CABLE WINCH NPKH 1

DESCRIPTION:

The NPKH 1 hydraulic belt and cable winch is a mechanical device hanging from a hanging track. NPKH 1 has a hydraulic motor that is connected to an auxiliary hydraulic circuit of a hanging locomotive (further only "LZH") through lever control after being connected using a hydraulic distributor connected to LZH. This hydraulic motor uses its power to turn the winch cylinder and thus to wind belts or cables placed on the floor of a mine tunnel.

The basic NPKH 1 parameters are the hydraulic power 1.1 MPa that is used on the hanging track with maximum 25° incline. NPKH 1 can be used for winding belts or cables only not for their transport. The maximum length of wound belt lining cannot exceed 100 m length, 1,200 mm width, and 4 000 kg weight. During transport of NPKH 1 to the place of manipulation with belt lining and back the prescribed transport speed of 6 km/hour cannot be exceeded.

NPKH 1 is a device that can be operated in the underground parts of mines that are classified with methane explosion danger according to Section 232, Par. 1, Letter b) and coal dust according to Section 233, Par. 1, Letter b) of the CBU Notice No. 22/1989 Coll., as amended, including mines with the danger of rock falls and gas outbursts, and mines with dangerous mining tremors.

NPKH 1 must be turned in longitudinal position to the hanging track and secured by a pin for the whole time of its transport to the place of manipulation with a belt lining. After the transport to the place of manipulation with a belt lining or cable the NPKH 1 must be unlocked and turned by 90° in such way that it is perpendicular to the hanging track. During winching the NPKH 1 is secured on the hanging track by LZH brakes and connected to LZH by a connecting rod with secured pins.

The end of belt lining (cable) is attached to NPKH 1, secured to the winching cylinder by two M 16 bolts and winching is started. The total length of winched belt may not exceed 100 m. If the length of belt lining is longer than 50 m, the belt must be folded in two in such way that no more than 50 m is pulled along the floor of the mining tunnel in order to lower pulling resistance.

After winching the rolled belt lining can be lowered to the floor and released using a push out cylinder that is a part of NPKH 1. Then the winch cylinder can be pulled vertically up and the rig can be moved away from the rolled belt lining in order not to be caught in it. Then NPKH 1 needs to be turned 90°, so it is longitudinal to the hanging track and secured in this position by a pin. After being secured by the pin against turning, NPKH 1 is ready for transport.



TECHNICAL PARAMETERS:

Belt winding pulling force	[N]	
Max. travel speed on level surface	[km.h. ⁻¹]	6
Belt winding installed power	[kW]	10
Hydraulic circuit operational pressure	[MPa]	16
Inside diameter of the supply hose	[mm]	DN 10
Max. belt length	[m]	100
Max. width of belt	[mm]	1 200
Max. weight of belt	[kg]	4 000
Dimensions – h x w x l	[mm]	2135,5 x 340 x 1146 (1656)
Weight	[kg]	

PNEUMATIC PLASTERING PUMP CPS 80 – 15kW

DESCRIPTION:

The CPS 80-15kW pneumatic plaster pump is used for transport of liquids and substances such as gypsum, ash and others with the maximum solid particle size of 5mm.

The CPS 80-15kW pneumatic plaster pump consists of a steel frame with the MPZ 15kW pneumatic gear motor with single-spindle 80-EFS pump. The pump has a removable hopper with a sieve and a rack. The density of pumped mixture in the pump can be regulated using pressure water.

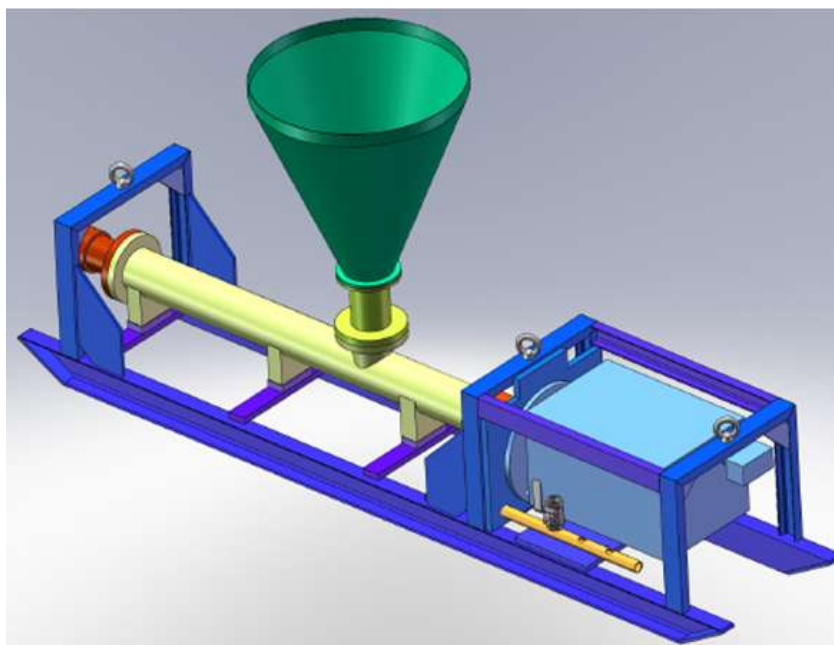

TECHNICAL PARAMETERS:

Nominal pressure at the discharge outlet	[MPa]	1,2
Nominal flow per revolution	[cm ³]	500
Outlet neck	[mm]	80
Motor operational pressure	[MPa]	0,4
Nominal motor output	[kW]	15
Nominal revs	[mm ⁻¹]	450
Air consumption	[m ³ h ⁻¹]	950
Filtration	[μm]	50
Basic dimensions (w x l x h)	[mm]	610 x 2210 x 1309
Weight	[kg]	450
Air supply	[mm]	Ø 50mm

PNEUMATIC SPINDLE PUMP WITH HOPPER CPVP

DESCRIPTION:

The CPVP pneumatic spindle pump with hopper is used for transport of liquids and substances such as gypsum, ash and others with the maximum solid particle size of 5mm.

The CPVP pneumatic spindle pump with hopper consists of a steel frame with hopper and feeding screw powered by a multi-plate motor, single spindle EFS 250 pump powered by a multi-plate motor and pneumatic and water distribution. Density of pumped mixture in the pump can be regulated using pressure water.

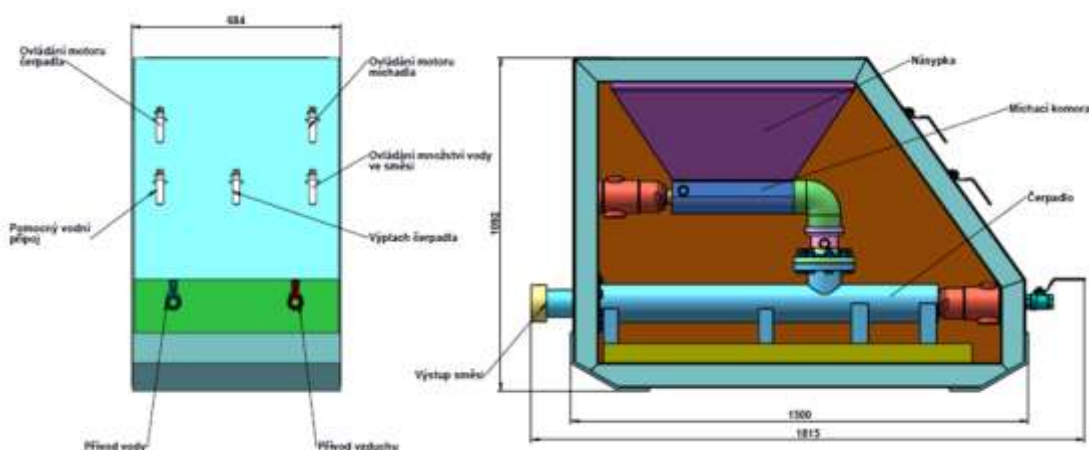

TECHNICAL PARAMETERS:

Nominal pressure at the discharge outlet	[MPa]	0,6
Outlet neck	[mm]	50
Transport output	[m ³ h ⁻¹]	cca 2,5
Motor operational pressure	[MPa]	0,4
Nominal motor output	[kW]	2 x 3
Nominal spindle revolutions	[min ⁻¹]	300
Air consumption	[m ³ h ⁻¹]	2 x 144
Filtration	[µm]	50
Basic dimensions (w x l x h)	[mm]	
Weight	[kg]	cca 200
Air supply	[mm]	Ø 32mm

ENCLOSED CONTAINER WITH HYDRAULIC OUTPUT SCREW KUHV 2

DESCRIPTION:

The KUHV 2 enclosed container with hydraulic output screw is used for transport of bulk material like ash and similar materials with the max. solid particle size of 5 mm.

The KUHV 2 enclosed container with hydraulic output screw consists of a steel frame with opening lid and screw output mechanism at the bottom that is powered by a hydraulic motor. The container can be transported along a hanging track or on a UNI undercarriage.

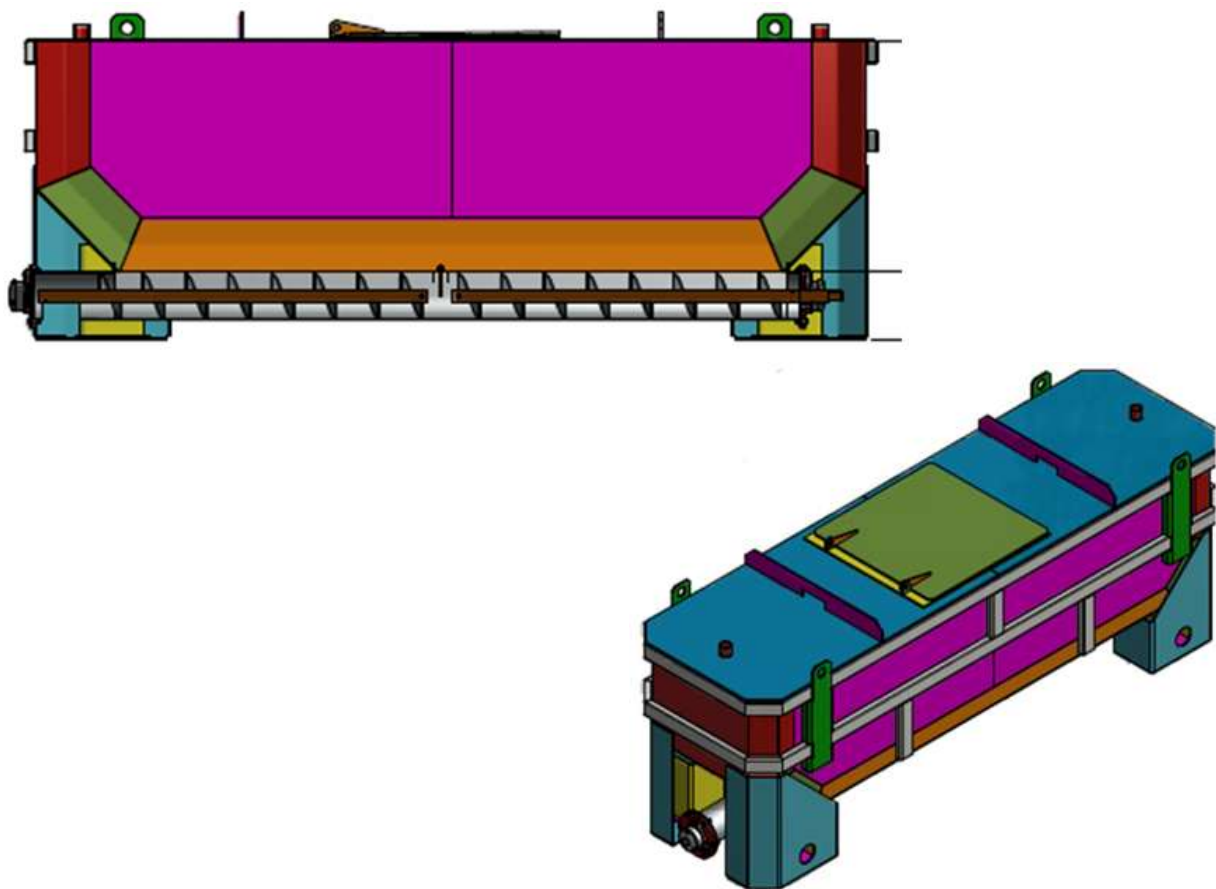

TECHNICAL PARAMETERS:

Container volume	[m ³]	2
Operational oil pressure - max.	[MPa]	17,5
Nominal motor output	[kW]	12,5
Screw feeder revs - max.	[min ⁻¹]	55
Basic dimensions (w x l x h)	[mm]	3170 x 930 x 11100
Weight	[kg]	approx. 950
Work medium		Oil, HPL VG-46

THE MPB 140 PNEUMATIC DRUM MIXER

DESCRIPTION:

The MPB 140 pneumatic drum mixer can be used for mixing of concrete and construction mixtures in the explosion danger environment.

The MPB 154 pneumatic drum mixer consists of the pipe frame, steel drum that is driven by the pneumatic engine through a worm-gear unit and the pneumatic distribution box with control.



TECHNICAL PARAMETERS:

Operating pressure	[MPa]	0,4-06
Nominal motor output	[kW]	1,8
Drum volume	[l]	140
Mixture volume	[l]	85/105
Air consumption	[m ³ min ⁻¹]	2,1
Filtration	[µm]	50
Basic dimensions	[mm]	1260 x 1330 x 750
Weight	[kg]	cca 80
Inside diameter of the supply hose	[mm]	Ø 19mm